

Oscilloscope HM 1004-3 .01/.02/.03

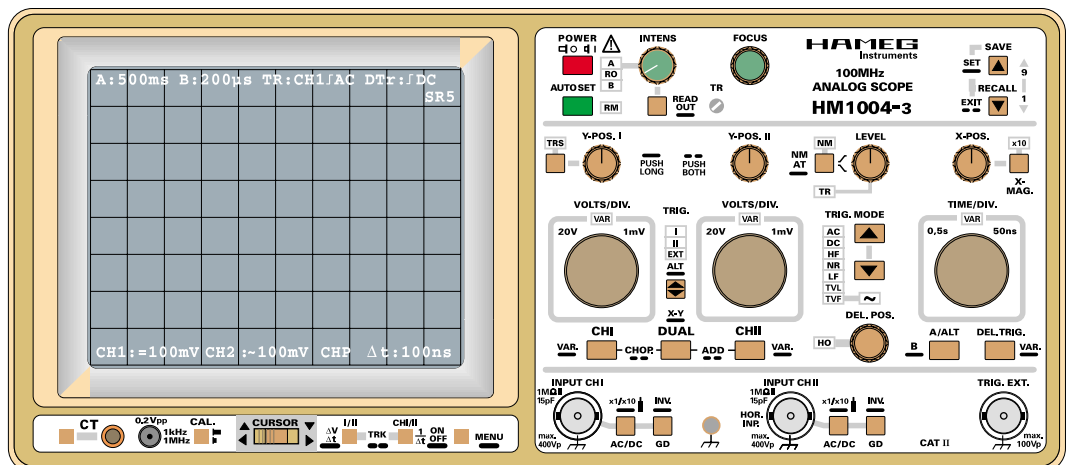

General information regarding the CE marking	4		
General Information	6		
Symbols	6		
Use of tilt handle	6		
Safety	6		
Intended purpose and operating conditions	6		
EMC	7		
Warranty	7		
Maintenance	7		
Protective Switch-Off	7		
Power supply	7		
Type of signal voltage	8		
Amplitude Measurements	8		
Total value of input voltage	9		
Time Measurements	9		
Connection of Test Signal	10		
Controls and Readout	11		
Menu	21		
First Time Operation	21		
Trace Rotation TR	21		
Probe compensation and use	21		
Adjustment at 1kHz	22		
Adjustment at 1MHz	22		
Operating modes of the vertical amplifiers in Yt mode	23		
X-Y Operation	23		
Phase comparison with Lissajous figures	23		
Phase difference measurement in DUAL mode (Yt)	24		
Phase difference measurement in DUAL mode	24		
Measurement of amplitude modulation	24		
Triggering and timebase	25		
Automatic Peak (value) -Triggering	25		
Normal Triggering	25		
$\sqrt{\quad}$ Slope	25		
Trigger coupling	26		
Triggering of video signals	26		
Line triggering (~)	26		
Alternate triggering	27		
External triggering	27		
Trigger indicator "TR"	27		
HOLD OFF-time adjustment	27		
B-Timebase (2nd Timebase)/ Triggering after Delay	28		
Auto Set	28		
		Component Tester	29
		General	29
		Using the Component Tester	29
		Test Procedure	29
		Test Pattern Displays	29
		Testing Resistors	29
		Testing Capacitors and Inductors	29
		Testing Semiconductors	29
		Testing Diodes	30
		Testing Transistors	30
		In-Circuit Tests	30
		Adjustments	31
		RS232 Interface - Remote Control	31
		Safety	31
		Operation	31
		Baud-Rate Setting	31
		Data Communication	31
		Front Panel HM1004-3	32



Herstellers
Manufacturer
Fabricant

HAMEG GmbH
Kelsterbacherstraße 15-19
D - 60528 Frankfurt

Bezeichnung / Product name / Designation:

Oszilloskop/Oscilloscope/Oscilloscope

Typ / Type / Type: HM1004-3

mit / with / avec: -

Optionen / Options / Options: -

mit den folgenden Bestimmungen / with applicable regulations / avec les directives suivantes

EMV Richtlinie 89/336/EWG ergänzt durch 91/263/EWG, 92/31/EWG
EMC Directive 89/336/EEC amended by 91/263/EWG, 92/31/EEC
Directive EMC 89/336/CEE amendée par 91/263/EWG, 92/31/CEE

Niederspannungsrichtlinie 73/23/EWG ergänzt durch 93/68/EWG
Low-Voltage Equipment Directive 73/23/EEC amended by 93/68/EEC
Directive des équipements basse tension 73/23/CEE amendée par 93/68/CEE

KONFORMITÄTSERKLÄRUNG
DECLARATION OF CONFORMITY
DECLARATION DE CONFORMITE

HAMEG
Instruments

Angewendete harmonisierte Normen / Harmonized standards applied / Normes harmonisées utilisées

Sicherheit / Safety / Sécurité

EN 61010-1: 1993 / IEC (CEI) 1010-1: 1990 A 1: 1992 / VDE 0411: 1994
EN 61010-1/A2: 1995 / IEC 1010-1/A2: 1995 / VDE 0411 Teil 1/A1: 1996-05
Überspannungskategorie / Overvoltage category / Catégorie de surtension: II
Verschmutzungsgrad / Degree of pollution / Degré de pollution: 2

Elektromagnetische Verträglichkeit / Electromagnetic compatibility / Compatibilité électromagnétique

EN 61326-1/A1

Störaussendung / Radiation / Emission: Tabelle / table / tableau 4; Klasse / Class / Classe B.

Störfestigkeit / Immunity / Imunitee: Tabelle / table / tableau A1.

EN 61000-3-2/A14

Oberschwingungsströme / Harmonic current emissions / Émissions de courant harmonique: Klasse / Class / Classe D.

EN 61000-3-3

Spannungsschwankungen u. Flicker / Voltage fluctuations and flicker / Fluctuations de tension et du flicker.

Datum /Date /Date

27.03.2001

Unterschrift / Signature / Signatur

E. Baumgartner

Technical Manager / Directeur Technique

General information regarding the CE marking

HAMEG instruments fulfill the regulations of the EMC directive. The conformity test made by HAMEG is based on the actual generic- and product standards. In cases where different limit values are applicable, HAMEG applies the severer standard. For emission the limits for residential, commercial and light industry are applied. Regarding the immunity (susceptibility) the limits for industrial environment have been used.

The measuring- and data lines of the instrument have much influence on emission and immunity and therefore on meeting the acceptance limits. For different applications the lines and/or cables used may be different. For measurement operation the following hints and conditions regarding emission and immunity should be observed:

1. Data cables

For the connection between instruments resp. their interfaces and external devices, (computer, printer etc.) sufficiently screened cables must be used. Without a special instruction in the manual for a reduced cable length, the maximum cable length of a dataline must be less than 3 meters and not be used outside buildings. If an interface has several connectors only one connector must have a connection to a cable.

Basically interconnections must have a double screening. For IEEE-bus purposes the double screened cables HZ72S and HZ72L from HAMEG are suitable.

2. Signal cables

Basically test leads for signal interconnection between test point and instrument should be as short as possible. Without instruction in the manual for a shorter length, signal lines must be less than 3 meters and not be used outside buildings.

Signal lines must be screened (coaxial cable - RG58/U). A proper ground connection is required. In combination with signal generators double screened cables (RG223/U, RG214/U) must be used.

3. Influence on measuring instruments.

Under the presence of strong high frequency electric or magnetic fields, even with careful setup of the measuring equipment an influence of such signals is unavoidable.

This will not cause damage or put the instrument out of operation. Small deviations of the measuring value (reading) exceeding the instruments specifications may result from such conditions in individual cases.

4. RF immunity of oscilloscopes.

4.1 Electromagnetic RF field

The influence of electric and magnetic RF fields may become visible (e.g. RF superimposed), if the field intensity is high. In most cases the coupling into the oscilloscope takes place via the device under test, mains/line supply, test leads, control cables and/or radiation. The device under test as well as the oscilloscope may be effected by such fields.

Although the interior of the oscilloscope is screened by the cabinet, direct radiation can occur via the CRT gap. As the bandwidth of each amplifier stage is higher than the total -3dB bandwidth of the oscilloscope, the influence RF fields of even higher frequencies may be noticeable.

4.2 Electrical fast transients / electrostatic discharge

Electrical fast transient signals (burst) may be coupled into the oscilloscope directly via the mains/line supply, or indirectly via test leads and/or control cables. Due to the high trigger and input sensitivity of the oscilloscopes, such normally high signals may effect the trigger unit and/or may become visible on the CRT, which is unavoidable. These effects can also be caused by direct or indirect electrostatic discharge.

HAMEG GmbH

Analog Oscilloscope HM1004-3 (100MHz)

Autoset, Save / Recall, Readout / Cursor and RS-232 Interface

Specifications

Vertical Deflection

Operating modes: Channel I or II separate,
Channel I and II: alternate or chopped

Chopper Frequency: approx. 0.5MHz

Sum or difference: from CH I and CH II

Invert: both channels

XY-Mode: via channel I (Y) and channel II(X)

Frequency range: 2x DC to 100MHz (-3dB)

Risetime: <3.5ns

Overshoot: ≤1%

Deflection coefficients: 14 calibrated steps
1mV to 20V/div.: ±5% (DC – 10MHz (-3dB))
5mV/div. to 20V/div.: ±3% in 1-2-5 sequence,
with variable 2.5:1 up to 50V/div.

Input impedance: 1MΩ || 15pF

Input coupling: DC-AC-GD (ground).

Input voltage: max. 400V (DC + peak AC).

Delay line: approx. 70ns

Triggering

Automatic (peak to peak): ≤20Hz-200MHz (≥ 0.5div.)

Normal with level control: DC-200MHz (≥0.5div.)

Indicator for trigger action: LED

Slope: positive or negative

Sources: Channel I or II, line and external.

ALT. Triggering: CH I/CH II (≥0.8div.)

Coupling: AC (10Hz – 200MHz),
DC (0 to 200MHz), HF (50kHz – 200MHz),
LF (0 to 1.5kHz), NR(noise reject):0-50MHz (≥ 0.8div.)

Triggering time base B: normal with level
control and slope selection (0 – 200 MHz)

Active TV Sync. Separator: field & line, + / -

External: ≥0.3V_{pp} (0 – 100MHz)

Horizontal Deflection

Time base A: 22 calibrated steps (±3%)
from 0.5s/div. – 50ns/div. in 1-2-5 sequence
variable 2.5:1 up to 1.25s/div., with
5ns/div. (±5%)

X-Mag. x10: 5ns/div. (±5%)

Holdoff time: variable to approx. 10:1

Time base B: 18 calibrated steps (±3%)
from 20ms/div. to 50ns/div. in 1-2-5 sequence

Operating modes: A or B, alternate A/B

Bandwidth X-amplifier: 0 to 3MHz (-3dB)

Input X-amplifier: via Channel II

Sensitivity: see Ch II

X-Y phase shift: <3° below 220kHz.

Operation / Control

Manual (front panel switches)

Auto Set (automatic parameter selection)

Save/Recall: 9 user-defined parameter settings

Readout: Display of parameter settings

Cursor measurement: ΔV, Δt or Δ1/t (frequ.)

Remote control: with built in RS-232 interface

Component Tester

Test voltage: approx. 7V_{rms} (open circuit).

Test current: approx. 7mA_{rms} (shorted).

General Information

CRT: D14-375GH, 8x10div., internal graticule

Acceleration voltage: approx 14kV

Trace rotation: adjustable on front panel

Calibrator: 1μ, 0.2V ±1%, ≈ 1kHz/1MHz (t_r <4ns)

Line voltage: 100-240V AC ±10%, 50/60Hz

Power consumption: approx. 38 Watt at 50Hz

Min./Max. ambient temperature: 0°C...+40°C

Protective system: Safety class I (IEC1010-1)

Weight: approx. 5.9kg. **Color:** techno-brown

Cabinet: W 285, H 125, D 380 mm

Subject to change without notice. 08/00



2 Channels, 1mV – 20V/div, Delay Line, 14kV CRT

Time Base A: 0.5s – 5ns/div., B: 20ms–5ns/div. , 2nd Trigger

Triggering DC–200MHz, Automatic Peak to Peak,

Alternate Trigger, Calibrator and Component Tester

This **microprocessor** controlled oscilloscope has been designed for a wide multitude of applications in service and industry. For ease of operation the „Autoset“ function allows for signal related **automatic setup** of measuring parameters. On screen **alphanumeric readout** and **cursor functions** for voltage, time and frequency measurement provide extraordinary operational convenience. Nine different user defined instrument settings can be saved and recalled without restriction. The **built-in RS-232** serial interface allows for remote controlled operation by a PC .

The outstanding features of the **HM1004-3** include two vertical input channels and the second time base with the ability to magnify, over 1000 times, extremely small portions of the input signal. The **second time base** has its own triggering controls, including level and slope selection, to allow a stable and precisely referenced display of asynchronous or jittery signal segments. The trigger circuit is designed to provide reliable triggering to over **200MHz** at signal levels as low as **0.5div.**. An active **TV Sync Separator** for TV-signal tracing ensures accurate triggering even with noisy signals. Signals are solid and distortion free even at the upper frequency limit. The built in **Y delay line** allows for leading edge display of even low repetition rate signals, supported by the **14kV CRT** with its high intensity. Both instruments are equipped with a built in **COMPONENT TESTER**.

Because it is so important to be able to trust the accuracy of the display when viewing pulse or square signals, the **HM1004-3** has a built-in switchable calibrator, which checks the instrument's transient response characteristics - from probe tip to CRT screen. The essential high frequency compensation of wide band probes can be performed with this calibrator, which features a rise time of less than 4ns.

The instrument offers the right combination of triggering control, frequency response, and time base versatility to facilitate measurements in a wide range of applications - in laboratory as well as in field service use. It is another example of **HAMEG's** dedication to engineering excellence.

Accessories supplied:

Line Cord, Operators Manual on CD-ROM, 2 Probes 10:1

General Information

General Information

This oscilloscope is easy to operate. The logical arrangement of the controls allows anyone to quickly become familiar with the operation of the instrument, however, experienced users are also advised to read through these instructions so that all functions are understood.

Immediately after unpacking, the instrument should be checked for mechanical damage and loose parts in the interior. If there is transport damage, the supplier must be informed immediately. The instrument must then not be put into operation.

Symbols



ATTENTION - refer to manual



Danger - High voltage



Protective ground (earth) terminal

Use of tilt handle

To view the screen from the best angle, there are three different positions (C, D, E) for setting up the instrument. If the instrument is set down on the floor after being carried, the handle automatically remains in the upright carrying position (A). In order to place the instrument onto a horizontal surface, the handle should be turned to the upper side of the oscilloscope (C). For the D position (10° inclination), the handle should be turned to the opposite direction of the carrying position until it locks in place automatically underneath the instrument. For the E position (20° inclination), the handle should be pulled to release it from the D position and swing backwards until it locks once more. The handle may also be set to a position for horizontal carrying by turning it to the upper side to lock in the B position. At the same time, the instrument must be lifted, because otherwise the handle will jump back.

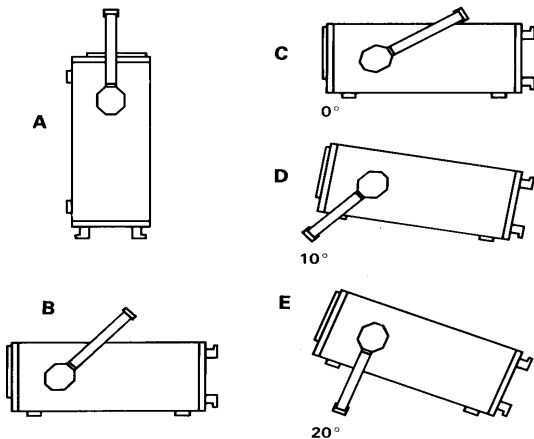

Safety

This instrument has been designed and tested in accordance with **IEC Publication 1010-1** (overvoltage category II, pollution degree 2), Safety requirements for electrical equipment for measurement, control, and laboratory use. The CENELEC regulations EN 61010-1 correspond to this standard. It has left the factory in a safe condition. This instruction manual contains important information and warnings which have to be followed by the user to ensure safe operation and to retain the oscilloscope in a safe condition.

The case, chassis and all measuring terminals are connected to the protective earth contact of the appliance inlet. The

instrument operates according to **Safety Class I** (three-conductor power cord with protective earthing conductor and a plug with earthing contact).

The mains/line plug shall only be inserted in a socket outlet provided with a protective earth contact. The protective action must not be negated by the use of an extension cord without a protective conductor.

The mains/line plug must be inserted before connections are made to measuring circuits.

The grounded accessible metal parts (case, sockets, jacks) and the mains/line supply contacts (line/live, neutral) of the instrument have been tested against insulation breakdown with 2200V DC.

Under certain conditions, 50Hz or 60Hz hum voltages can occur in the measuring circuit due to the interconnection with other mains/line powered equipment or instruments. This can be avoided by using an isolation transformer (Safety Class II) between the mains/line outlet and the power plug of the device being investigated.

Most cathode-ray tubes develop X-rays. **However, the dose equivalent rate falls far below the maximum permissible value of 36pA/kg (0.5mR/h).**

Whenever it is likely that protection has been impaired, the instrument shall be made inoperative and be secured against any unintended operation. The protection is likely to be impaired if, for example, the instrument

- shows visible damage,
- fails to perform the intended measurements,
- has been subjected to prolonged storage under unfavourable conditions (e.g. in the open or in moist environments),
- has been subject to severe transport stress (e.g. in poor packaging).

Intended purpose and operating conditions

This instrument must be used only by qualified experts who are aware of the risks of electrical measurement.

The instrument is specified for operation in industry, light industry, commercial and residential environments.

Due to safety reasons the instrument must only be connected to a properly installed power outlet, containing a protective earth conductor. The protective earth connection must not be broken. The power plug must be inserted in the power outlet while any connection is made to the test device.

The instrument has been designed for indoor use. The permissible ambient temperature range during operation is +10°C (+50°F) ... +40°C (+104°F). It may occasionally be subjected to temperatures between +10°C (+50°F) and -10°C (+14°F) without degrading its safety. The permissible ambient temperature range for storage or transportation is -40°C (-40°F) ... +70°C (+158°F). The maximum operating altitude is up to 2200m (non-operating 15000m). The maximum relative humidity is up to 80%.

If condensed water exists in the instrument it should be acclimatized before switching on. In some cases (e.g. extremely cold oscilloscope) two hours should be allowed before the instrument is put into operation. The instrument should be kept in a clean and dry room and must not be operated in explosive, corrosive, dusty, or moist environments. The oscilloscope can be operated in any position, but the convection cooling must not be impaired. The ventilation

holes may not be covered. For continuous operation the instrument should be used in the horizontal position, preferably tilted upwards, resting on the tilt handle.

The specifications stating tolerances are only valid if the instrument has warmed up for 30 minutes at an ambient temperature between +15°C (+59°F) and +30°C (+86°F). Values without tolerances are typical for an average instrument.

EMC

This instrument conforms to the European standards regarding the electromagnetic compatibility. The applied standards are: Generic immunity standard EN50082-2:1995 (for industrial environment) Generic emission standard EN50081-1:1992 (for residential, commercial and light industry environment).

This means that the instrument has been tested to the highest standards.

Please note that under the influence of strong electromagnetic fields, such signals may be superimposed on the measured signals.

Under certain conditions this is unavoidable due to the instrument's high input sensitivity, high input impedance and bandwidth. Shielded measuring cables, shielding and earthing of the device under test may reduce or eliminate those effects.

Warranty

HAMEG warrants to its Customers that the products it manufactures and sells will be free from defects in materials and workmanship **for a period of 2 years**. This warranty shall not apply to any defect, failure or damage caused by improper use or inadequate maintenance and care. **HAMEG** shall not be obliged to provide service under this warranty to repair damage resulting from attempts by personnel other than **HAMEG** representatives to install, repair, service or modify these products.

In order to obtain service under this warranty, Customers must contact and notify the distributor who has sold the product. Each instrument is subjected to a quality test with 10 hour burn-in before leaving the production. Practically all early failures are detected by this method. In the case of shipments by post, rail or carrier the original packing must be used. Transport damages and damage due to gross negligence are not covered by the guarantee.

In the case of a complaint, a label should be attached to the housing of the instrument which describes briefly the faults observed. If at the same time the name and telephone number (dialing code and telephone or direct number or department designation) is stated for possible queries, this helps towards speeding up the processing of guarantee claims.

Maintenance

Various important properties of the oscilloscope should be carefully checked at certain intervals. Only in this way is it largely certain that all signals are displayed with the accuracy on which the technical data are based. Purchase of the **HAMEG scope tester HZ 60**, which despite its low price is highly suitable for tasks of this type, is very much recommended. The exterior of the oscilloscope should be cleaned regularly with a dusting brush. Dirt which is difficult to remove on the casing and handle, the plastic and aluminium parts, can be removed with a moistened cloth (99% water +1% mild detergent). Spirit or washing benzine (petroleum

ether) can be used to remove greasy dirt. The screen may be cleaned with water or washing benzine (but not with spirit (alcohol) or solvents), it must then be wiped with a dry clean lint-free cloth. Under no circumstances may the cleaning fluid get into the instrument. The use of other cleaning agents can attack the plastic and paint surfaces.

Protective Switch Off

This instrument is equipped with a switch mode power supply. It has both over voltage and overload protection, which will cause the switch mode supply to limit power consumption to a minimum. In this case a ticking noise may be heard.

Power supply

The instrument operates on mains/line voltages between 100V_{AC} and 240V_{AC}. No means of switching to different input voltages has therefore been provided.

The power input fuse is externally accessible. The fuse holder and the 3 pole power connector is an integrated unit. The power input fuse can be exchanged after the rubber connector is removed. The fuse holder can be released by lever action with the aid of a screwdriver. The starting point is a slot located on contact pin side. The fuse can then be pushed out of the mounting and replaced.

The fuse holder must be pushed in against the spring pressure and locked. Use of patched fuses or short circuiting of the fuse holder is not permissible; **HAMEG** assumes no liability whatsoever for any damage caused as a result, and all warranty claims become null and void.

Fuse type:
Size 5x20mm; 0.8A, 250V AC fuse;
must meet IEC specification 127,
Sheet III (or DIN 41 662
or DIN 41 571, sheet 3).

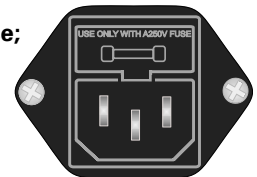

Time characteristic: time lag.

Attention!
There is a fuse located inside the instrument within the switch mode power supply:

Size 5x20mm; 0.8A, 250V AC fuse;
must meet IEC specification 127,
Sheet III (or DIN 41 662
or DIN 41 571, sheet 3).
Time characteristic: fast (F).

The operator must not replace this fuse!

Type of signal voltage

Type of signal voltage

The oscilloscopes **HM1004-3** and **HM1505-3** allow examination of DC voltages and most repetitive signals in the frequency range up to at least 100MHz (-3dB) in case of **HM1004-3** or 150MHz for the **HM1505-3**.

The vertical amplifiers have been designed for minimum overshoot and therefore permit a true signal display. The display of sinusoidal signals within the bandwidth limits causes no problems, but an increasing error in measurement due to gain reduction must be taken into account when measuring high frequency signals. These errors become noticeable at approx. **40MHz (HM1004-3)** or **70MHz (HM1505-3)**. At approx. 80 MHz (HM1505-3: 110 MHz) the reduction is approx. 10% and the real voltage value is 11% higher. The gain reduction error can not be defined exactly as the -3dB bandwidth of the amplifiers differ between **100MHz and 140MHz (HM1004-3)**; and **150MHz and 170MHz (HM1505-3)**.

For sine wave signals the -6dB limits are approx. 160MHz for the HM1004-3 and 220MHz in the case of the HM1505-3.

When examining square or pulse type waveforms, attention must be paid to the harmonic content of such signals. The repetition frequency (fundamental frequency) of the signal must therefore be significantly smaller than the upper limit frequency of the vertical amplifier.

Displaying composite signals can be difficult, especially if they contain no repetitive higher amplitude content which can be used for triggering. This is the case with bursts, for instance. To obtain a well-triggered display in this case, the assistance of the variable holdoff function or the second timebase may be required. Television video signals are relatively easy to trigger using the built-in TV-Sync-Separator (TV).

For optional operation as a DC or AC voltage amplifier, each vertical amplifier input is provided with a DC/AC switch. DC coupling should only be used with a series-connected attenuator probe or at very low frequencies or if the measurement of the DC voltage content of the signal is absolutely necessary.

When displaying very low frequency pulses, the flat tops may be sloping with AC coupling of the vertical amplifier (AC limit frequency approx. 1.6 Hz for 3dB). In this case, DC operation is preferred, provided the signal voltage is not superimposed on a too high DC level. Otherwise a capacitor of adequate capacitance must be connected to the input of the vertical amplifier with DC coupling. This capacitor must have a sufficiently high breakdown voltage rating. DC coupling is also recommended for the display of logic and pulse signals, especially if the pulse duty factor changes constantly. Otherwise the display will move upwards or downwards at each change. Pure direct voltages can only be measured with DC-coupling.

The input coupling is selectable by the AC/DC pushbutton. The actual setting is displayed in the readout with the " = " symbol for DC- and the " ~ " symbol for AC coupling.

Amplitude Measurements

In general electrical engineering, alternating voltage data normally refers to effective values (rms = root-mean-square value). However, for signal magnitudes and voltage designa-

tions in oscilloscope measurements, the peak-to-peak voltage (V_{pp}) value is applied. The latter corresponds to the real potential difference between the most positive and most negative points of a signal waveform.

If a sinusoidal waveform, displayed on the oscilloscope screen, is to be converted into an effective (rms) value, the resulting peak-to-peak value must be divided by $2 \times \sqrt{2} = 2.83$. Conversely, it should be observed that sinusoidal voltages indicated in V_{rms} (V_{eff}) have 2.83 times the potential difference in V_{pp} . The relationship between the different voltage magnitudes can be seen from the following figure.

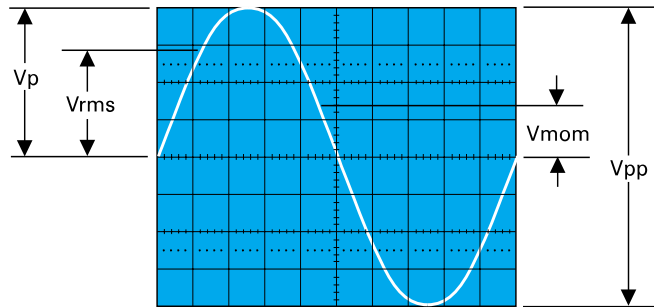

Voltage values of a sine curve

V_{rms} = effective value; V_p = simple peak or crest value; V_{pp} = peak-to-peak value; V_{mom} = momentary value.

The minimum signal voltage which must be applied to the Y input for a trace of 1div height is 1mVpp ($\pm 5\%$) when this deflection coefficient is displayed on the screen (readout) and the vernier is switched off (VAR-LED dark). However, smaller signals than this may also be displayed. The deflection coefficients are indicated in mV/div or V/div (peak-to-peak value).

The magnitude of the applied voltage is ascertained by multiplying the selected deflection coefficient by the vertical display height in div. If an attenuator probe $\times 10$ is used, a further multiplication by a factor of 10 is required to ascertain the correct voltage value.

For exact amplitude measurements, the variable control (VAR) must be set to its calibrated detent CAL position.

With the variable control activated the deflection sensitivity can be reduced up to a ratio of 2.5 to 1 (**please note "controls and readout"**). Therefore any intermediate value is possible within the 1-2-5 sequence of the attenuator(s).

With direct connection to the vertical input, signals up to 400Vpp may be displayed (attenuator set to 20V/div, variable control to 2.5:1).

With the designations

- H** = display height in div,
- U** = signal voltage in Vpp at the vertical input,
- D** = deflection coefficient in V/div at attenuator switch,

the required value can be calculated from the two given quantities:

$$U = D \cdot H \quad H = \frac{U}{D} \quad D = \frac{U}{H}$$

However, these three values are not freely selectable. They have to be within the following limits (trigger threshold, accuracy of reading):

H between 0.5 and 8div, if possible 3.2 to 8div,
U between 0.5mVpp and 160Vpp,
D between 1mV/div and 20V/div in 1-2-5 sequence.

Examples:

Set deflection coefficient **D** = 50mV/div 0.05V/div,
 observed display height **H** = 4.6div,
 required voltage **U** = 0.05x4.6 = 0.23Vpp.

Input voltage **U** = 5Vpp,
 set deflection coefficient **D** = 1V/div,
 required display height **H** = 5:1 = 5div.

Signal voltage **U** = 230Vrmsx $\sqrt{2}$ = 651Vpp
 (voltage > 160Vpp, with probe 10:1: **U** = 65.1Vpp),
 desired display height **H** = min. 3.2div, max. 8div,
 max. deflection coefficient **D** = 65.1:3.2 = 20.3V/div,
 min. deflection coefficient **D** = 65.1:8 = 8.1V/div,
 adjusted deflection coefficient **D** = 10V/div.

The previous examples are related to the crt graticule reading. The results can also be determined with the aid of the ΔV cursor measurement (**please note "controls and readout"**). The input voltage must not exceed 400V, independent from the polarity.

If an AC voltage which is superimposed on a DC voltage is applied, the maximum peak value of both voltages must not exceed + or -400V. So for AC voltages with a mean value of zero volt the maximum peak to peak value is 800Vpp.

If attenuator probes with higher limits are used, the probes limits are valid only if the oscilloscope is set to DC input coupling.

If DC voltages are applied under AC input coupling conditions the oscilloscope maximum input voltage value remains 400V. The attenuator consists of a resistor in the probe and the 1M Ω input resistor of the oscilloscope, which are disabled by the AC input coupling capacity when AC coupling is selected. This also applies to DC voltages with superimposed AC voltages.

It also must be noted that due to the capacitive resistance of the AC input coupling capacitor, the attenuation ratio depends on the signal frequency. For sinewave signals with frequencies higher than 40Hz this influence is negligible.

With the above listed exceptions **HAMEG** 10:1 probes can be used for DC measurements up to 600V or AC voltages (with a mean value of zero volt) of 1200Vpp. The 100:1 probe **HZ53** allows for 1200V DC or 2400Vpp for AC.

It should be noted that its AC peak value is derated at higher frequencies. If a normal x10 probe is used to measure high voltages there is the risk that the compensation trimmer bridging the attenuator series resistor will break down causing damage to the input of the oscilloscope.

However, if for example only the residual ripple of a high voltage is to be displayed on the oscilloscope, a normal x10 probe is sufficient. In this case, an appropriate high voltage capacitor (approx. 22-68nF) must be connected in series with the input tip of the probe. With **Y-POS.** control (input coupling to **GD**) it is possible to use a **horizontal graticule line as reference line for ground potential before the measurement.** It can lie below or above the horizontal central line according to whether positive and/or negative deviations from the ground potential are to be measured.

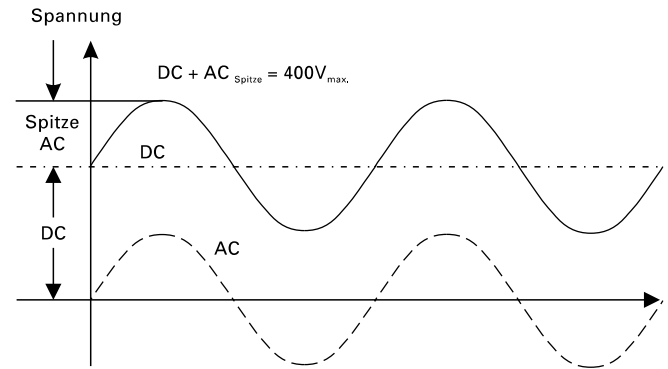

Total value of input voltage

The dotted line shows a voltage alternating at zero volt level. If superimposed on a DC voltage, the addition of the positive peak and the DC voltage results in the max. voltage (DC + ACpeak).

Time Measurements

As a rule, most signals to be displayed are periodically repeating processes, also called periods. The number of periods per second is the repetition frequency. Depending on the timebase setting (**TIME/DIV.**-knob) indicated by the readout, one or several signal periods or only a part of a period can be displayed. The time coefficients are stated in **ms/div**, **μ s/div** or **ns/div**. The following examples are related to the crt graticule reading. The results can also be determined with the aid of the ΔT and $1/\Delta T$ cursor measurement (**please note "Controls and Readout"**).

The duration of a signal period or a part of it is determined by multiplying the relevant time (horizontal distance in div) by the (calibrated) time coefficient displayed in the readout. Uncalibrated, the timebase speed can be reduced until a maximum factor of 2.5 is reached. Therefore any intermediate value is possible within the 1-2-5 sequence.

With the designations

- L** = displayed wave length in div of one period,
- T** = time in seconds for one period,
- F** = recurrence frequency in Hz of the signal,
- Tc** = time coefficient in ms, μ s or ns/div and the relation **F** = 1/T, the following equations can be stated:

$$T = L \cdot T_c \quad L = \frac{T}{T_c} \quad T_c = \frac{T}{L}$$

$$F = \frac{1}{L \cdot T_c} \quad L = \frac{1}{F \cdot T_c} \quad T_c = \frac{1}{L \cdot F}$$

However, these four values are not freely selectable. They have to be within the following limits:

- L** between 0.2 and 10div, if possible 4 to 10div,
- T** between 5ns and 5s,
- F** between 0.5Hz and 100MHz,
- Tc** between 50ns/div and 500ms/div in 1-2-5 sequence (with X-MAG. (x10) inactive), and
- Tc** between 5ns/div and 50ms/div in 1-2-5 sequence (with X-MAG. (x10) active).

Examples:

Displayed wavelength **L** = 7div,
 set time coefficient **Tc** = 100ns/div,
 required period **T** = 7x100x10⁻⁹ = 0.7 μ s
 required rec. freq. **F** = 1:(0.7x10⁻⁶) = 1.428MHz.
 Signal period **T** = 1s,

Type of signal voltage

set time coefficient $T_c = 0.2\text{s/div}$,
 required wavelength $L = 1:0.2 = 5\text{div}$.
 Displayed ripple wavelength $L = 1\text{div}$,
 set time coefficient $T_c = 10\text{ms/div}$,
 required ripple freq. $F = 1:(1 \times 10 \times 10^{-3}) = 100\text{Hz}$.
 TV-Line frequency $F = 15625\text{Hz}$,
 set time coefficient $T_c = 10\mu\text{s/div}$,
 required wavelength $L = 1:(15\ 625 \times 10^{-5}) = 6.4\text{div}$.
 Sine wavelength $L = \text{min. } 4\text{div, max. } 10\text{div}$,
 Frequency $F = 1\text{kHz}$,
 max. time coefficient $T_c = 1:(4 \times 10^3) = 0.25\text{ms/div}$,
 min. time coefficient $T_c = 1:(10 \times 10^3) = 0.1\text{ms/div}$,
 set time coefficient $T_c = 0.2\text{ms/div}$,
 required wavelength $L = 1:(10^3 \times 0.2 \times 10^{-3}) = 5\text{div}$.
 Displayed wavelength $L = 0.8\text{div}$,
 set time coefficient $T_c = 0.5\mu\text{s/div}$,
 pressed X-MAG. (x10) button: $T_c = 0.05\mu\text{s/div}$,
 required rec. freq. $F = 1:(0.8 \times 0.05 \times 10^{-6}) = 25\text{MHz}$,
 required period $T = 1:(25 \times 10^6) = 40\text{ns}$.

If the time is relatively short as compared with the complete signal period, an expanded time scale should always be applied (X-MAG. (x10) active). In this case, the time interval of interest can be shifted to the screen center using the X-POS. control.

When investigating pulse or square waveforms, the critical feature is the risetime of the voltage step. To ensure that transients, ramp-offs, and bandwidth limits do not unduly influence the measuring accuracy, the risetime is generally measured between 10% and 90% of the vertical pulse height. For measurement, adjust the Y deflection coefficient using its variable function (uncalibrated) together with the Y-POS. control so that the pulse height is precisely aligned with the 0% and 100% lines of the internal graticule. The 10% and 90% points of the signal will now coincide with the 10% and 90% graticule lines. The risetime is given by the product of the horizontal distance in div between these two coincident points and the calibrated time coefficient setting. The fall time of a pulse can also be measured by using this method.

The following figure shows correct positioning of the oscilloscope trace for accurate risetime measurement.

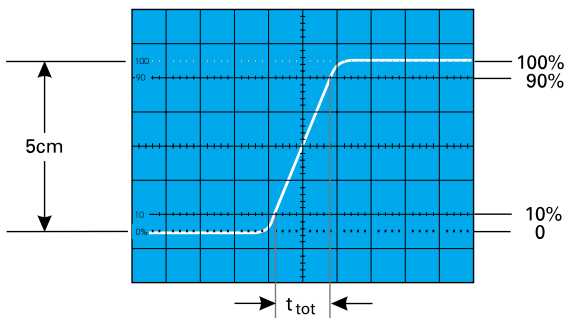

With a time coefficient of 5ns/div (X x10 magnification active), the example shown in the above figure results in a total measured risetime of

$$t_{\text{tot}} = 1.6\text{div} \times 5\text{ns/div} = \mathbf{8\text{ns}}$$

When very fast risetimes are being measured, the risetimes of the oscilloscope amplifier and of the attenuator probe has to be deducted from the measured time value. The risetime of the signal can be calculated using the following formula.

$$t_r = \sqrt{t_{\text{tot}}^2 - t_{\text{osc}}^2 - t_p^2}$$

In this t_{tot} is the total measured risetime, t_{osc} is the risetime of the oscilloscope amplifier (HM1004-3 approx. 3.5ns) and t_p

the risetime of the probe (e.g. = 2ns). If t_{tot} is greater than 34ns , then t_{tot} can be taken as the risetime of the pulse, and calculation is unnecessary.

Calculation of the example in the figure above results in a signal risetime

$$t_r = \sqrt{8^2 - 3,5^2 - 2^2} = \mathbf{6,9\text{ns}}$$

The measurement of the rise or fall time is not limited to the trace dimensions shown in the above diagram. It is only particularly simple in this way. In principle it is possible to measure in any display position and at any signal amplitude. It is only important that the full height of the signal edge of interest is visible in its full length at not too great steepness and that the horizontal distance at 10% and 90% of the amplitude is measured. If the edge shows rounding or overshooting, the 100% should not be related to the peak values but to the mean pulse heights. Breaks or peaks (glitches) next to the edge are also not taken into account. With very severe transient distortions, the rise and fall time measurement has little meaning. For amplifiers with approximately constant group delay (therefore good pulse transmission performance) the following numerical relationship between rise time t_r (in ns) and bandwidth B (in MHz) applies:

$$t_r = \frac{350}{B} \quad B = \frac{350}{t_r}$$

Connection of Test Signal

In most cases briefly depressing the **AUTO SET** causes a useful signal related instrument setting. The following explanations refer to special applications and/or signals, demanding a manual instrument setting. **The description of the controls is explained in the section "controls and readout".**

Caution:

When connecting unknown signals to the oscilloscope input, always use automatic triggering and set the input coupling switch to AC (readout). The attenuator should initially be set to 20V/div.

Sometimes the trace will disappear after an input signal has been applied. Then a higher deflection coefficient (lower input sensitivity) must be chosen until the vertical signal height is only 3-8div. With a signal amplitude greater than 160Vpp and the deflection coefficient (**VOLTS/DIV.**) in calibrated condition, an attenuator probe must be inserted before the vertical input. If, after applying the signal, the trace is nearly blanked, the period of the signal is probably substantially longer than the set time deflection coefficient (**TIME/DIV.**). It should be switched to an adequately larger time coefficient.

The signal to be displayed can be connected directly to the Y-input of the oscilloscope with a shielded test cable such as **HZ32** or **HZ34**, or reduced through a x10 or x100 attenuator probe. The use of test cables with high impedance circuits is only recommended for relatively low frequencies (up to approx. 50kHz). For higher frequencies, the signal source must be of low impedance, i.e. matched to the characteristic resistance of the cable (as a rule 50Ω). Especially when transmitting square and pulse signals, a resistor equal to the characteristic impedance of the cable must also be connected across the cable directly at the Y-input of the oscilloscope. When using a 50Ω cable such as the **HZ34**, a 50Ω through termination type **HZ22** is available from **HAMEG**. When transmitting square signals with short rise times, transient phenomena on the edges and top of the signal may become

visible if the correct termination is not used. A terminating resistance is sometimes recommended with sine signals as well. Certain amplifiers, generators or their attenuators maintain the nominal output voltage independent of frequency only if their connection cable is terminated with the prescribed resistance. Here it must be noted that the terminating resistor **HZ22** will only dissipate a maximum of 2Watts. This power is reached with $10V_{rms}$ or at $28.3V_{pp}$ with sine signal. If a x10 or x100 attenuator probe is used, no termination is necessary. In this case, the connecting cable is matched directly to the high impedance input of the oscilloscope. When using attenuator probes, even high internal impedance sources are only slightly loaded (approx. $10M\Omega \parallel 12pF$ or $100M\Omega \parallel 5pF$ with **HZ53**). Therefore, if the voltage loss due to the attenuation of the probe can be compensated by a higher amplitude setting, the probe should always be used. The series impedance of the probe provides a certain amount of protection for the input of the vertical amplifier. Because of their separate manufacture, all attenuator probes are only partially compensated, therefore accurate compensation must be performed on the oscilloscope (see Probe compensation).

Standard attenuator probes on the oscilloscope normally reduce its bandwidth and increase the rise time. In all cases where the oscilloscope bandwidth must be fully utilized (e.g. for pulses with steep edges) we strongly advise using the probes **HZ51** (x10) **HZ52** (x10 HF) and **HZ54** (x1 and x10). This can save the purchase of an oscilloscope with larger bandwidth.

The probes mentioned have a HF-calibration in addition to low frequency calibration adjustment. Thus a group delay correction to the upper limit frequency of the oscilloscope is possible with the aid of a 1MHz calibrator, e.g. **HZ60**.

In fact the bandwidth and rise time of the oscilloscope are not noticeably changed with these probe types and the waveform reproduction fidelity can even be improved because the probe can be matched to the oscilloscope's individual pulse response.

If a x10 or x100 attenuator probe is used, DC input coupling must always be used at voltages above 400V. With AC coupling of low frequency signals, the attenuation is no longer independent of frequency, pulses can show pulse tilts. Direct voltages are suppressed but load the oscilloscope input coupling capacitor concerned. Its voltage rating is max. 400 V (DC + peak AC). DC input coupling is therefore of quite special importance with a x100 attenuation probe which usually has a voltage rating of max. 1200 V (DC + peak AC). A capacitor of corresponding capacitance and voltage rating may be connected in series with the attenuator probe input for blocking DC voltage (e.g. for hum voltage measurement).

With all attenuator probes, **the maximum AC input voltage** must be derated with frequency usually above 20kHz. Therefore the derating curve of the attenuator probe type concerned must be taken into account.

The selection of the ground point on the test object is important when displaying small signal voltages. It should always be as close as possible to the measuring point. If this is not done, serious signal distortion may result from spurious currents through the ground leads or chassis parts. The ground leads on attenuator probes are also particularly critical. They should be as short and thick as possible. When the attenuator probe is connected to a BNC-socket, a BNC-

adapter, should be used. In this way ground and matching problems are eliminated. Hum or interference appearing in the measuring circuit (especially when a small deflection coefficient is used) is possibly caused by multiple grounding because equalizing currents can flow in the shielding of the test cables (voltage drop between the protective conductor connections, caused by external equipment connected to the mains/line, e.g. signal generators with interference protection capacitors).

Controls and Readout

The following description assumes that the instrument is not set to "COMPONENT TESTER" mode.

If the instrument is switched on, all important settings are displayed in the readout. The LED's located on the front panel assist operation and indicate additional information. Incorrect operation and the electrical end positions of control knobs are indicated by a warning beep.

Except for the power pushbutton (**POWER**), the calibrator frequency pushbutton (**CAL. 1kHz/1MHz**), the focus control (**FOCUS**) and the trace rotation control (**TR**) all other controls are electronically selected. All other functions and their settings can therefore be remote controlled and stored.

The front panel is subdivided into sections.

On the top, immediately to the right of the CRT screen, the following controls and LED indicators are placed:

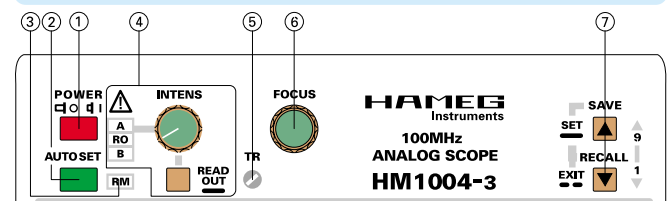

(1) POWER - Pushbutton and symbols for **ON (I)** and **OFF (O)**.

After the oscilloscope is switched on, all LEDs are lit and an automated instrument test is performed. During this time the **HAMEG** logo and the software version are displayed on the screen. After the internal test is completed successfully, the overlay is switched off and the normal operation mode is present. Then the last used settings become activated and one LED indicates the ON condition.

Some mode functions can be modified (**SETUP**) and/or automated adjustment procedures (**CALIBRATE**) can be called if the "**MAIN MENU**" is present. **For further information please note "MENU"**.

(2) AUTO SET -

Briefly depressing this pushbutton (**please note "AUTO SET"**) automatically selects Yt mode. The instrument is set to the last used Yt mode setting (CH I, CH II or DUAL). Even if alternating timebase mode or B timebase mode was active before, the instrument is switched automatically to A timebase mode. **Please note "AUTO SET"**.

Automatic CURSOR supported voltage measurement
If CURSOR voltage measurement is present, the CURSOR lines are automatically set to the positive and negative peak value of the signal. The accuracy of this function decreases with higher frequencies and is also influenced by the signal's pulse duty factor.

Controls and Readout

In DUAL mode the CURSOR lines are related to the signal which is used for internal triggering.

If the signal height is insufficient, the CURSOR lines do not change.

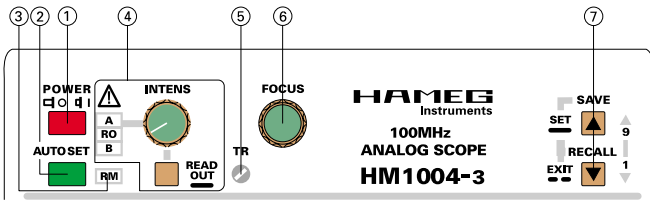

(3) RM -

The remote control mode can be switched on or off via the RS232 interface. In the latter case the "RM" LED is lit and the electronically selectable controls on front panel are inactive. This state can be left by depressing the **AUTO SET** pushbutton provided it was not deactivated via the interface.

(4) INTENS - READOUT

Knob with associated pushbutton and LEDs.

This control knob is for adjusting the A and B traces and readout intensity. Turning this knob clockwise increases and turning it counterclockwise decreases the intensity.

The **READOUT** pushbutton below is for selecting the function in two ways.

Depending on the actual timebase mode and with the readout (RO) not switched off, briefly pressing the **READOUT** pushbutton switches over the **INTENS** knob function indicated by a LED in the sequences:

A - RO - A in condition A timebase,
 A - RO - B - A if alternate timebase mode is present and
 B - RO - B in condition B timebase.

XY mode: A - RO - A.
 Component Test: A - RO - A.

Pressing and holding the **READOUT** pushbutton switches the readout on or off. In readout off condition the **INTENS** knob function can consequently not be set to **RO**. Briefly pressing the pushbutton causes the following sequences:

condition	sequence
A timebase	A - A
Alternate A/B	A - B - A
B timebase	B - B
XY mode	A - A
Component Test	A - A

Switching the readout off, may be required if interference is visible on the signal(s). Such interference may also originate from the chopper generator if the instrument is operated in chopped **DUAL** mode.

With the exception of the letters "CT" all other READ-OUT information is switched off in COMPONENT TEST mode. All INTENS settings are stored after the instrument is switched off.

The **AUTOSET** function switches the readout on and selects A timebase mode (A-LED lit). The **INTENS** setting for each function is automatically set to the mean value, if less intensity was previously selected.

(5) TR

The trace rotation control can be adjusted with a small screwdriver (**please note "trace rotation TR"**)

(6) FOCUS

This control knob effects both the trace and the readout sharpness.

(7) SAVE / RECALL

The instrument contains 9 non volatile memories. These can be used by the operator to save instrument settings and to recall them. This relates to all settings with the exception of **FOCUS**, **TR** (trace rotation) and the calibrator frequency pushbutton.

Press the **SAVE** pushbutton briefly to start the save procedure. The readout then indicates the letter "S" followed by a cipher between 1 and 9, indicating the memory location. If the instrument settings stored in this memory location must not be overwritten, briefly press the **SAVE** or the **RECALL** pushbutton to select another memory location. Each time the **SAVE** pushbutton is briefly pressed the memory location cipher increases until the location number 9 is reached. The **RECALL** pushbutton function is similar but decreases the memory location cipher until 1 is reached. Press and hold **SAVE** for approx. 3 seconds to write the instruments settings in the memory and to switch the associated readout information (e.g. "S8") off.

To recall a front panel setup, start that procedure by briefly pressing the **RECALL** pushbutton. The readout then indicates the letter "R" and the memory location number. If required, select a different memory location as described above. Recall the settings by pressing and holding the **RECALL** pushbutton for approx. 3 seconds.

Attention:
Make sure that the signal to be displayed is similar to the one that was present when the settings were stored. If the signal is different (frequency, amplitude) to the one during storage then a distorted display may result.

If the **SAVE** or the **RECALL** pushbutton was depressed inadvertently, briefly press both pushbuttons at the same time or wait approx. 10 seconds without pressing either pushbutton to exit that function.

Switching the instrument off automatically stores the actual settings in memory location 9, with the effect that different settings previously stored in this location get lost. To prevent this, **RECALL 9** before switching the instrument off.

Attention!
Both pushbuttons have a second function if the instrument is switched to menu operation. Please note "MENU".

The setting controls and LED's for the Y amplifiers, modes, triggering and timebases are located underneath the sector of the front panel described before.

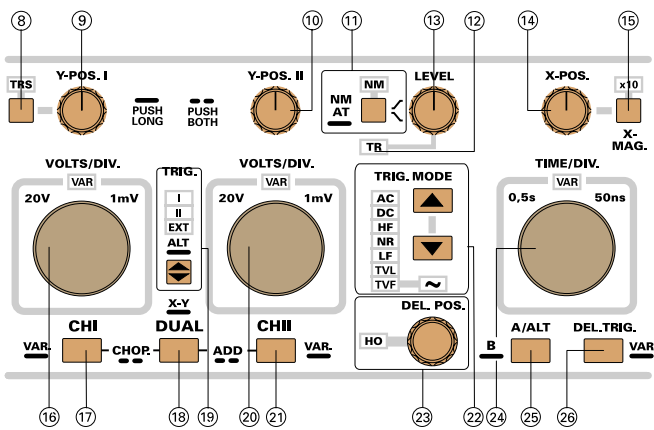

(8) TRS

The instrument contains a trace separation function which is required in the alternate timebase mode to separate the B timebase trace from the A timebase in Y direction. Consequently this function is only available in alternate timebase mode. After the TRS pushbutton was pressed once the LED related to that pushbutton is lit.

The **Y-POS. I** control knob is then operative as vertical position control for the trace of the B timebase. The maximum position shift is approx. +/- 4 div. Without a change of the **Y-POS. I** control the trace separation function is switched off automatically after approx. 10 seconds. The trace separation function can also be left by pressing the TRS pushbutton.

(9) Y-POS. I - Control knob with a double function.

Y-Position channel I:

The vertical trace position of channel I can be set with this control knob. In ADD (addition) mode both (Y-POS. I and Y-POS. II) control knobs are active.

Y-Position B-trace in alternate timebase mode:

In alternate timebase mode, this control knob can be used to separate the B timebase trace from the A timebase trace. **Please note TRS (8).**

DC voltage measurement:

If no signal is applied at the INPUT CHI (27), the vertical trace position represents 0 Volt. This is the case if INPUT CHI (27) or in addition (ADD) mode, both INPUT CHI (27) and INPUT CHII (31), are set to GD (ground) and automatic triggering (AT (11)) is present to make the trace visible. The trace then can be set to vertical position which is suited for the following DC voltage measurement.

After switching GD (ground) off and selecting DC input coupling, a DC signal applied at the input changes the trace position in vertical direction. The DC voltage then can be determined by taking the deflection coefficient, the probe factor and the trace position change in respect to the previous 0 Volt position into account.

"0 Volt" Symbol:

The determination of the "0 Volt" position is not necessary if the readout is switched on and the software setting "DC Ref. = ON" is selected in the "SETUP" submenu "Miscellaneous". Then the "⊥" symbol to the left of the screen's vertical center line always indicates the "0 Volt" trace position in CHI and DUAL mode.

The "0 Volt" position symbol (⊥) will not be displayed in

XY and ADD (addition) mode.

(10) Y-POS. II - Control knob.

The vertical trace position of channel II can be set with this control knob. In ADD (addition) mode both (Y-POS. I and Y-POS. II) control knobs are active. If the instrument is set to XY mode this control knob is inactive and the X-POS. knob must be used for a horizontal position shift.

DC voltage measurement:

If no signal is applied at the INPUT CHII (31), the vertical trace position represents 0 Volt. This is the case if INPUT CHII (31) or in addition (ADD) mode, both INPUT CHI (27) and INPUT CHII (31), are set to GD (ground) and automatic triggering (AT (11)) is present to make the trace visible. The trace then can be set to vertical position which is suited for the following DC voltage measurement.

After switching GD (ground) off and selecting DC input coupling, a DC signal applied at the input changes the trace position in vertical direction. The DC voltage then can be determined by taking the deflection coefficient, the probe factor and the trace position change in respect to the previous 0 Volt position into account.

"0 Volt" Symbol:

The determination of the "0 Volt" position is not necessary if the readout is switched on and the software setting "DC Ref. = ON" is selected in the "SETUP" submenu "Miscellaneous". Then the "⊥" symbol to the left of the screen's vertical center line always indicates the "0 Volt" trace position in CHI and DUAL mode.

The "0 Volt" position symbol (⊥) will not be displayed in XY and ADD (addition) mode.

(11) NM - AT - ∩ (SLOPE)

Pushbutton with a double function and associated NM-LED.

NM - AT selection:

Press and hold the pushbutton to switch over from automatic (peak value) to normal triggering (NM LED above the pushbutton lit) and vice versa. If the LED is dark, automatic (peak value) triggering is selected. Whether the peak value detection in automatic trigger mode is automatically activated or not, depends on the trigger coupling setting (TRIG.MODE). The way the trigger point symbol in the readout responds on different LEVEL control knob settings indicates the situation:

1. If the trigger symbol can not be shifted in the vertical direction when a signal is not applied or the signal height is not sufficient, the peak value detection is active.
2. Under the condition that the trigger point symbol cannot be shifted in such a way that it leaves the signal display on the screen, the peak value detection is active.
3. The peak value detection is switched off if the trigger point can be set outside the maximum peak values of the signal, thus causing an untriggered signal display.

∩ Slope selection:

Briefly pressing this pushbutton selects which slope of the signal is used for triggering the timebase generator.

Controls and Readout

Each time this pushbutton is briefly pressed, the slope direction switches from falling edge to rising edge and vice versa.

The current setting is displayed in the readout under item "TR: source, SLOPE, coupling". The last setting in A timebase mode is stored and still active if the alternate (A and B) or B timebase are selected. This allows for a different slope setting regarding the B timebase if the DEL. TRIG. function is active. The slope direction chosen for the B timebase is indicated in the readout under "DTR: SLOPE, coupling".

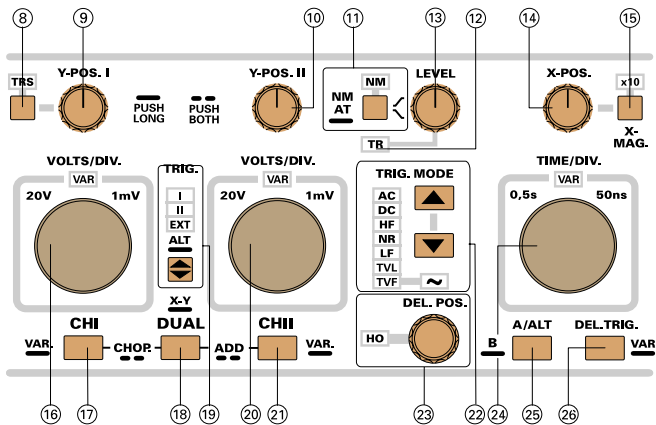

(12) TR - Trigger indicator LED.

The TR LED is lit in Yt mode if the triggering conditions are met. Whether the LED flashes or is lit constantly depends on the frequency of the trigger signal.

(13) LEVEL - Control knob.

Turning the **LEVEL** knob causes a different trigger point setting (voltage). The trigger unit starts the timebase when the edge of a trigger signal (voltage) crosses the trigger point. In most Yt modes the trigger point is displayed in the readout by the symbol on the left vertical graticule line. If the trigger point symbol would overwrite other readout information or would be invisible when being set above or below the screen, the symbol changes and an arrow indicates in which vertical direction the trigger point has left the screen.

The trigger point symbol is automatically switched off in those modes where there is no direct relation between the trigger signal and the displayed signal. The last setting in A timebase mode is stored and still active if alternate (A and B) or B timebase mode are selected.

This allows for a different level setting for the B timebase if the **DEL. TRIG.** function is active. Under this condition the letter "**B**" is added to the trigger point symbol.

(14) X-POS. - Control knob.

This control knob enables an X position shift of the signal(s) in Yt and XY mode. In combination with X magnification x10 this function makes it possible to shift any part of the signal on the screen.

(15) X-MAG. x10 - Pushbutton and LED.

Each time this pushbutton is pressed the x10 LED located above is switched on or off. If the x10 LED is lit, the signal display in all Yt and timebase modes is expanded 10 fold and consequently only a tenth part of the signal curve is visible. The interesting part of the signal can be made visible with aid of the **X-POS.** control. As the X expansion

results in a higher timebase speed (lower time deflection coefficient), all time and frequency relevant information in the readout is switched over.

Please note that in alternate timebase mode the intensified sector may become invisible due to the X position setting.

This pushbutton is not operative in XY mode.

(16) VOLTS/DIV.

This control knob for channel I has a double function.

The following description relates to the input attenuator function (VAR LED dark).

Turning the control knob clockwise increases the sensitivity in a 1-2-5 sequence and decreases it if turned in the opposite direction (ccw.). The available range is from 1mV/div up to 20V/div. The knob is automatically switched inactive if the channel related to it is switched off, or if the input coupling is set to **GD** (ground).

The deflection coefficients and additional information regarding the active channels are displayed in the readout, e.g. "Y1: deflection coefficient, input coupling". The ":" symbolizes calibrated measuring conditions and is replaced by the ">" symbol in uncalibrated conditions.

(17) CH I - VAR. - Pushbutton with several functions.

CH I mode:

Briefly pressing the **CH I** button sets the instrument to channel I (Mono CH I) mode. The deflection coefficient displayed in the readout indicates the current conditions ("Y1..."). If neither external nor line (mains) triggering was active, the internal trigger source automatically switches over to channel I ("TR:Y1..."). The last function setting of the **VOLTS/DIV (16)** knob remains unchanged.

All channel I related controls are active if the **input (27)** is not set to **GD (29)**.

VAR.:

Pressing and holding this pushbutton selects the **VOLTS/DIV. (16)** control knob function between attenuator and vernier (variable). The current setting is displayed by the **VAR-LED** located above the knob.

After switching the **VAR-LED (16)** on, the deflection coefficient is still calibrated. Turning the **VOLTS/DIV. (16)** control knob counter clockwise reduces the signal height and the deflection coefficient becomes uncalibrated.

The readout then displays e.g. "Y1>..." indicating the uncalibrated condition instead of "Y1:...". Pressing and holding the CH I pushbutton again switches the LED off, sets the deflection coefficient into calibrated condition and activates the attenuator function. The previous vernier setting will not be stored.

The **CH I** pushbutton can also be pressed simultaneously with the **DUAL(18)** button. **Please note item (18).**

(18) DUAL - XY - Pushbutton with multiple functions.

DUAL mode:

Briefly pressing this button switches over to DUAL mode.

Both deflection coefficients are then displayed. The previous trigger setting stays as it was, but can be changed.

All controls related to both channels are active, if the inputs (27) and (31) are not set to **GD (29) (33)**.

Whether alternated or chopped channel switching is present depends on the actual timebase setting, and is displayed in the readout.

ALT

displayed in the readout, indicates alternate channel switching. After each timebase sweep the instrument internally switches over from channel I to channel II and vice versa. This channel switching mode is automatically selected if any time coefficient from 200µs/div to 50ns/div is active.

CHP

indicates chopper mode, whereby the channel switching occurs constantly between channel I and II during each sweep. This channel switching mode occurs when any timebase setting between 500ms/div and 500µs/div has been chosen.

The actual channel switching can be changed to the opposite mode by briefly pressing both **CHI (17)** and **DUAL (18)** simultaneously. If afterwards the time coefficient is changed, the channel switching is automatically set to the time coefficient related mode.

ADD mode:

Addition mode can be selected by briefly pressing the **DUAL (18)** and **CHII (21)** buttons simultaneously. Whether the algebraic sum (addition) or the difference (subtraction) of both input signals is displayed, depends on the phase relationship and the **INV (29) (33)** setting(s). As a result both signals are displayed as one signal. For correct measurements the deflection coefficients for both channels must be equal.

Please note "Operating modes of the vertical amplifiers in Yt mode".

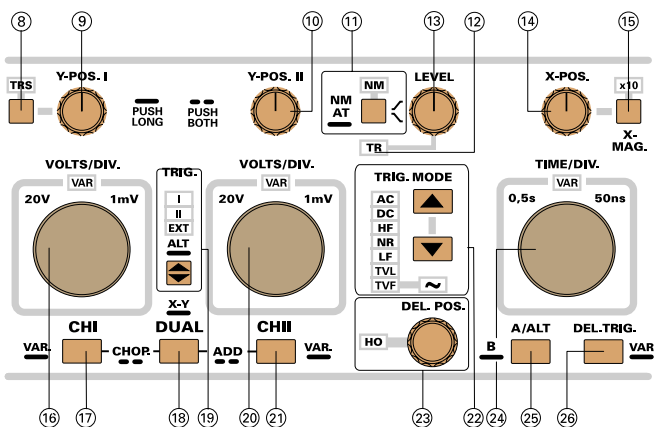

The readout indicates this mode by a "+" sign located between both channel deflection coefficients. While the trigger mode is not affected, the trigger point symbol is switched off. The Y-position of the signal can be influenced by both **Y-POS** controls (9) and (10).

XY mode:

This mode can be switched on or off by pressing and holding the **DUAL (18)**.

In **XY** mode the deflection coefficients are displayed as "**Y...**" for channel I and "**X...**" for channel II, followed by "**XY**". Except the cursor lines which may be active, all other readout information including the trigger point symbol are switched off. In addition to all trigger and timebase related controls, the **Y-POS. II (10)** knob and **INV (33)** button are deactivated. For X position alteration, the **X-POS. (14)** knob can be used.

(19)TRIG.

Pushbutton with double function for trigger source selection and associated LEDs.

The button and the LEDs are deactivated if line (mains) triggering is selected or XY operation is chosen.

With the aid of this button, the trigger source can be chosen. There are three trigger sources available:

channel I, channel II (both designated as internal trigger sources) and the **TRIG. EXT. (34)** input for external triggering.

The availability of the internal sources depends on the actual channel mode. The actual setting is indicated by the associated LED(s).

Briefly pressing the button switches over in the following sequence:

- I - II - EXT - I in DUAL and ADD (addition) mode,
- I - EXT - I if mono channel I is present,
- II - EXT - II under mono channel II conditions.

Each condition is indicated by the associated LED and displayed by the readout ("**TR:Y1...**", "**TR:Y2...**" and "**TR:EXT...**"). The trigger point symbol is switched off in external trigger condition.

ALT:

Pressing and holding the button selects alternate triggering in **DUAL** mode. Under these conditions both I and II LEDs are lit and the readout displays "**TR:ALT...**". As alternate triggering requires alternate channel operation, alternate channel switching is set automatically. A change of the time coefficient then has no affect regarding the channel switching mode. In addition to the deflection coefficients display, "**ALT**" is displayed by the readout instead of "**CHP**".

In alternate trigger mode the trigger point symbol is switched off.

Alternate triggering is not available or automatically switched off under the following conditions:

- ADD** (addition) mode,
- alternate** (A & B) timebase mode,
- B** timebase mode,
- TVL, TVF** and **line** (mains) trigger coupling.

(20) VOLTS/DIV. -

This control knob for channel II has a double function.

The following description relates to the input attenuator function (VAR LED dark).

Turning the control knob clockwise increases the sensitivity in a 1-2-5 sequence and decreases it if turned in the opposite direction (ccw.). The available range is from

Controls and Readout

1 mV/div up to 20V/div. The knob is automatically switched inactive if the channel related to it is switched off, or if the input coupling is set to **GD** (ground).

The deflection coefficients and additional information regarding the active channels are displayed in the readout, e.g. "Y2: deflection coefficient, input coupling". The ":", symbolizes calibrated measuring conditions and is replaced by the ">" symbol in uncalibrated conditions.

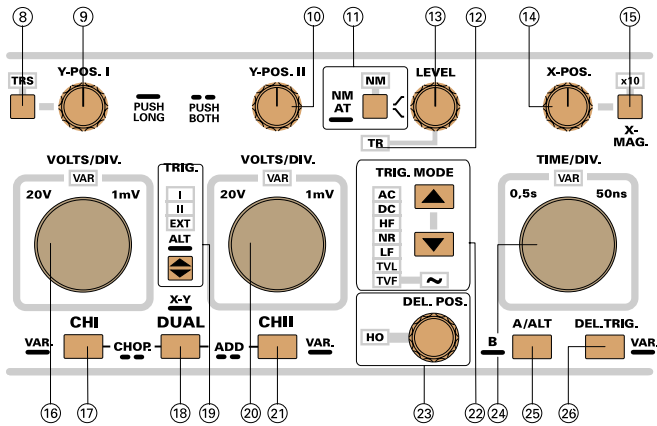

(21)CH II - VAR. - Pushbutton with several functions.

CH II mode:

Briefly pressing the button sets the instrument to channel II (Mono CH II) mode. The deflection coefficient displayed in the readout indicates the current conditions ("Y2..."). If neither external nor line (mains) triggering was active, the internal trigger source automatically switches over to channel II ("TR:Y2..."). The last function setting of the **VOLTS/DIV (20)** knob remains unchanged.

All channel related controls are active if the input (31) is not set to **GD (33)**.

VAR.:

Pressing and holding this pushbutton selects the **VOLTS/DIV. (20)** control knob function between attenuator and vernier (variable). The current setting is displayed by the **VAR-LED** located above the knob.

After switching the **VAR-LED (20)** on, the deflection coefficient is still calibrated. Turning the **VOLTS/DIV. (20)** control knob counter clockwise reduces the signal height and the deflection coefficient becomes uncalibrated.

The readout then displays "Y2>..." indicating the uncalibrated condition instead of "Y2:...". Pressing and holding the **CHII** pushbutton again switches the LED off, sets the deflection coefficient into calibrated condition and activates the attenuator function. The previous vernier setting will not be stored.

The **CHII** pushbutton can also be pressed simultaneously with the **DUAL (18)** button. **Please note item (18)**.

(22)TRIG. MODE - Pushbuttons and indicator LEDs.

Pressing the upper or lower button selects the trigger coupling. The actual setting is indicated by a LED and by the readout ("TR: source, slope, AC").

Each time the lower **TRIG. MODE** pushbutton is pressed the trigger coupling changes in the sequence:

- AC** (DC content suppressed),
- DC** (peak value detection inactive),
- HF** (high-pass filter cuts off frequencies below approx. 50kHz), trigger point symbol switched off
- NR** (high frequency noise rejected),
- LF** (low-pass filter cuts off frequencies above approx. 1.5kHz),
- TVL** (TV signal, line pulse triggering) trigger point symbol switched off,
- TVF** (TV signal, frame pulse triggering) trigger point symbol switched off.
- ~ (line/mains triggering) trigger point symbol and **TRIG. LED (19)** are switched off.

Please note:

In delay trigger mode (B timebase) the instrument is automatically set to normal triggering mode and DC trigger coupling. Neither setting is indicated by the **NM- (11)** or the "DC" **TRIG. MODE-LED**. The previous trigger settings regarding the A timebase remain unchanged and are indicated by the LEDs (11) and (22).

In some trigger modes such as alternate triggering, some trigger coupling modes are automatically disabled and can not be selected.

(23)DEL.POS. - HO

Control knob with a double function and associated LED.

This control knob has two different functions depending on the timebase mode.

A timebase:

In A timebase mode, the control knob applies to the hold off time setting. If the **HO-LED** associated with the knob is dark, the hold off time is set to minimum.

Turning the control knob clockwise switches the LED on and extends the hold off time until the maximum is reached (**please note "Hold Off-time adjustment"**). The hold off time is automatically set to minimum (LED dark), if the A timebase setting is changed. The (A) hold off time setting is stored and active if alternate (A and B) or B timebase mode is selected.

Alternate (A and B) and B timebase:

In alternate (A and B) and B timebase modes, the knob controls the delay time setting.

Under alternate timebase mode conditions, the delay time is visible on the A trace, beginning at the trace start and ending at the start of the intensified sector. In the free run condition (delay trigger not active) of the timebase, an approximate delay time value is displayed in the readout ("Δt:..."). This is an aid to find the position of the intensified sector which may be very small.

If only the B timebase is being operated, the delay time can also be varied, but there is no intensified sector as the A trace is not visible.

(24)TIME/DIV. - The control knob has a double function.

The following description applies to the timebase switch function (VAR LED dark).

Timebase Switch:

Turning the control knob clockwise reduces the deflection coefficient in a 1-2-5 sequence and increases it if turned in the opposite direction (ccw.). The time coefficient(s) is (are) displayed in the readout.

In A timebase mode, time deflection coefficients between 500ms/div and 50ns/div can be chosen in 1-2-5 sequence, if the X-MAG. x10 function is not activated.

During alternate (A and B) and B timebase operation, the control knob changes the B timebase setting in 1-2-5 sequence. The available deflection coefficient range is from 20ms/div up to 50ns/div (without X-MAG. x10) but the availability depends on the A timebase setting. The internal control of the oscilloscope prevents the B time deflection coefficient from becoming higher than the A deflection coefficient, as such an operation condition would make no sense.

If the A timebase setting is 200µs/div the B timebase range from 20ms/div up to 500µs/div is not available and the maximum time deflection coefficient for B would be 200µs/div. In the last named condition the change of the A timebase from 200µs/div to 100µs/div switches the B timebase also to 100µs/div. However the B timebase setting remains unchanged if the A timebase is set to 500µs/div.

As already mentioned under **DUAL (18)** the channel switching depends on the time deflection coefficient setting. In the timebase ranges from 500ms/div to 500µs/div chopped (CHP) channel switching is automatically selected, through which the switching occurs constantly during the timebase sweeps. Alternate (ALT) channel switching is automatically used in all other time deflection coefficient settings (200µs/div - 50ns/div). In the latter case the active channel is switched off and the previously inactive channel is switched on after the completion of each timebase sweep. To avoid interference in chopped mode, or to make both channels appear simultaneously visible, the actual setting (**ALT** or **CHP**) displayed in the readout can be overwritten and changed to the opposite mode. This is carried out by simultaneously pressing and holding the **CHI (17)** and the **DUAL (18)** pushbuttons.

(25) A/ALT - B - Pushbutton for timebase mode selection.

The instrument contains two timebases designated A and B. With the aid of the B timebase, signal parts displayed by the A timebase can be expanded in X-direction. The expansion ratio depends on the time deflection coefficient ratio of both timebases (e.g. "A: 100µs", "B: 1µs" = 100). With higher expansion ratios the B timebase trace intensity reduces.

Each time the **A/ALT** pushbutton is briefly pressed, the timebase mode changes in the sequence A - alternate A and B - A. The actual setting is displayed in the readout.

A:

In A timebase mode the **TIME/DIV. (24)** control knob is operative only for this timebase. The readout then only displays the A time coefficient. The timebase settings for this condition are stored if the timebase mode is changed.

ALT:

If alternate (A and B = ALT) timebase mode is selected, the **TIME/DIV (24)** knob only controls the B timebase switch or vernier function. The alternate timebase mode is a subfunction of the B timebase mode where both timebase traces are displayed. Consequently the readout displays both time deflection coefficients (e.g. "A: 100µs B: 1µs"). Unlike the former A timebase mode, an intensified sector is also visible on the A trace. This sector

indicates the signal part which is displayed by the B timebase.

The intensified segment can be shifted horizontally by the **DEL. POS. (23)** control knob continuously (if the B timebase is operated in free run conditions). The difference between the start of the A timebase trace and the beginning of the intensified sector shows the delay time. This information is also displayed in the readout as an approximative value (e.g. "Δt: 2.5ms") related on the calibrated A time coefficient (uncalibrated e.g. "Δt > 2.5ms"). The width of the segment decreases when the B time coefficient is set to a lower value (higher time deflection speed).

For better reading, the vertical position of the B trace position can be shifted (**please note "TRS" (8)**).

Alternate timebase mode causes the display to alter between A and B timebase after each sweep. In alternate DUAL mode the sequence is channel I with A timebase, channel I with B timebase, channel II with A timebase and channel II with B timebase.

B:

Pressing and holding this button switches over from A or alternate timebase mode to B timebase mode. If B timebase mode is selected, pressing and holding selects alternate timebase mode. Briefly pressing this button switches over from B timebase mode to A timebase mode.

In B timebase mode the display of the A trace(s), the intensified sector(s) and the A time coefficient display in the readout are disabled. As the trace separation (**TR**) is no longer required under this circumstances, this function is switched off too. Consequently only the B time coefficient is displayed by the readout.

If after switching on the B timebase (alternate or only B) whether free run or triggered B operation is present depends on the previous setting.

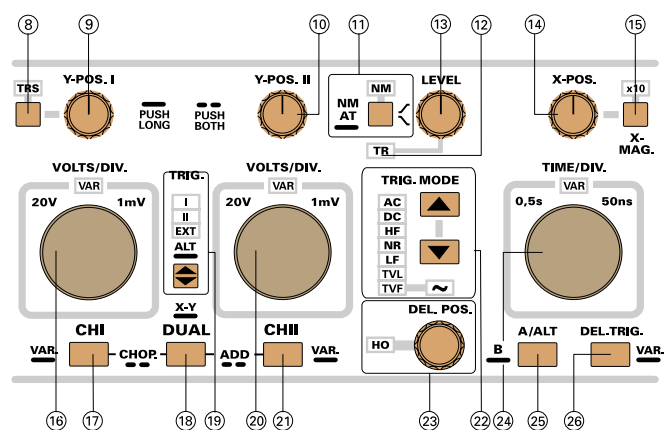

(26) DEL. TRIG. - VAR. - Pushbutton with two functions.

DEL. TRIG.:

Each time the pushbutton is briefly pressed, the instrument switches between free run (untriggered) and triggered B timebase, if alternate (A and B) or B timebase mode is present.

The actual setting is displayed in the readout. Instead of the approximate delay time ("Δt: ...") in free run mode, the readout displays "ΔTr: slope, DC (trigger coupling)"

Controls and Readout

in triggered delay mode. In this mode, the former A timebase trigger settings regarding the trigger mode (automatic or normal), -coupling, -slope and -level settings are stored but still active. With the activated delay trigger the instrument is automatically set to normal trigger mode and DC trigger coupling for the B timebase. As the instrument contains a separate trigger unit for the B timebase, the trigger level and slope can be set independently using the same controls used for the A timebase trigger setting. The trigger point is indicated again but has the added letter B in the readout.

In delay trigger mode, the delay time must first elapse. Then the next suitable signal slope (direction and height) starts the B timebase. If those basic requirements are not met, there will be no B trace visible. Under the condition that the signal contains several suitable slopes after the delay time, it can be seen in alternate timebase mode that the delay time setting (DEL. POS.) now causes the intensified sector to jump from one slope to the other.

VAR.:

Pressing and holding the **DEL.TRIG. - VAR.** pushbutton selects the **TIME/DIV. (24)** control knob function between timebase switch and vernier (variable). The current setting is displayed by the VAR-LED located above the knob.

The variable function can be activated for the A timebase or the B timebase, the settings are stored separately. As alternate timebase mode is a B timebase sub mode, only the B timebase is affected in this condition.

A Timebase.

After switching the **VAR-LED** on, the time deflection coefficient is still calibrated until further adjustments are made. Turning the **TIME/DIV. (24)** control knob counter clockwise increases the time deflection coefficient (reduces the deflection speed) and the deflection coefficient becomes uncalibrated. Instead of e.g. "A:10 μ s", the readout then displays "**A>10 μ s**" indicating the uncalibrated condition. This setting is stored if the instrument is switched to alternate (A and B) or B timebase mode.

Pressing and holding the **DEL.TRIG. - VAR.** pushbutton again in A timebase mode switches the LED off, the timebase switch function on, and sets the time deflection coefficient back into the calibrated condition.

B and Alternate Timebase.

In alternate (A and B) as well as in B timebase mode, pressing and holding the **DEL.TRIG. - VAR.** pushbutton selects the **TIME/DIV.** knob function between B timebase switch and B vernier (VAR-LED on). In the latter case the **TIME/DIV.** knob can be used in the same way as described before under A timebase condition.

Underneath the front panel sector described above, the BNC sockets and four pushbuttons are located.

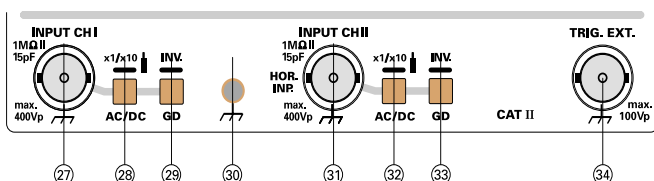

(27)INPUT CH I - BNC socket.

This BNC socket is the signal input for channel I. In XY mode, signals at this input are used for the Y deflection. The outer (ground) connection is galvanically connected to the instrument ground and consequently to the safety earth contact of the line/mains plug.

(28)AC / DC - Pushbutton with two functions.

Input coupling:

Briefly pressing this pushbutton switches over from AC (\sim symbol) to DC (= symbol) input coupling and vice versa. The setting is displayed in the readout with the deflection coefficient.

Probe factor:

Pressing and holding the pushbutton selects the indicated deflection coefficient of channel I displayed in the readout, between 1:1 and 10:1. In condition 10:1 the probe factor is thus indicated by a probe symbol displayed by the readout in front of the channel information (e.g. "probe symbol", Y1...). In the case of cursor voltage measurement, the probe factor is automatically included.

Please note:

The symbol must not be activated unless a x10 (10:1) attenuator probe is used.

(29)GD - INV. - Pushbutton with two functions.

GD:

Each time this pushbutton is pressed briefly, the input is switched from active to inactive and vice versa. It is displayed in the readout as an earth (ground) symbol instead of the deflection coefficient and the \sim (**AC**) or = (**DC**) symbol.

The GD setting disables the input signal, the **AC/DC (28)** pushbutton and the **VOLTS/DIV (16)** knob. In automatic trigger mode the undeflected trace is visible representing the 0 Volt trace position.

The "0 Volt" position is indicated by a " \perp " symbol in the readout. Please note **Y-POS. I (9)**.

INV.:

Pressing and holding this pushbutton switches the channel I invert function on or off. The invert "**on**" condition is indicated by the readout with a horizontal bar above "**Y1**" (Yt mode) or "**Y**" (XY mode). The invert function causes the signal display of channel I to be inverted by 180°.

(30)Ground socket - 4mm banana socket galvanically connected to safety earth.

This socket can be used as reference potential connection for **DC** and low frequency signal measurement purposes and in **COMPONENT TEST mode**.

(31)INPUT CH II - BNC socket.

This BNC socket is the signal input for channel II. In XY mode, signals at this input are used for the X deflection. The outer (ground) connection is galvanically connected to the instrument ground and consequently to the safety earth contact of the line/mains plug.

(32)AC / DC - Pushbutton with two functions.

Input coupling:

Briefly pressing this pushbutton switches over from AC (~ symbol) to DC (= symbol) input coupling and vice versa. The setting is displayed in the readout with the deflection coefficient.

Probe factor:

Pressing and holding the pushbutton selects the indicated deflection coefficient of channel II displayed in the readout, between 1:1 and 10:1. In condition 10:1 the probe factor is thus indicated by a probe symbol displayed by the readout in front the channel information (e.g. "probe symbol", Y2...). In the case of cursor voltage measurement, the probe factor is automatically included.

Please note:

The symbol must not be activated unless a x10 (10:1) attenuator probe is used.

(33)GD - INV. - Pushbutton with two functions.

GD:

Each time this pushbutton is pressed briefly, the input is switched from active to inactive and vice versa. It is displayed in the readout as an earth (ground) symbol instead of the deflection coefficient and the ~ (AC) or = (DC) symbol.

The GD setting disables the input signal, the **AC/DC (32)** pushbutton and the **VOLTS/DIV (20)** knob. In automatic trigger mode the undeflected trace is visible representing the 0 Volt trace position.

The "0 Volt" position is indicated by a "⊥" symbol in the readout. Please note **Y-POS. II (10)**.

INV.:

Pressing and holding this pushbutton switches the channel II invert function on or off. The invert "on" condition is indicated by the readout with a horizontal bar above "Y2" (Yt mode). The invert function causes the signal display of channel II to be inverted by 180°.

In XY mode the invert function of channel II is automatically switched off.

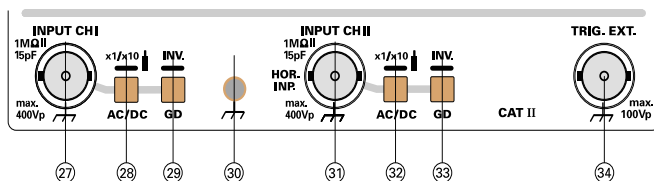

(34)TRIG. EXT.

This BNC socket is the external trigger signal input. Briefly pressing the **TRIG. (19)** pushbutton, until the information "TR:EXT, slope, coupling" is visible in the readout and the TRIG. "EXT" -LED is lit, switches the input active. The outer (ground) connection is galvanically connected to the instrument ground and consequently to the safety earth contact of the line/mains plug.

Below the CRT there are the controls for the readout, the component tester and the squarewave calibrator with their outputs.

Please note:

The following description of the cursor related controls assumes that the readout is visible and the component tester is switched off.

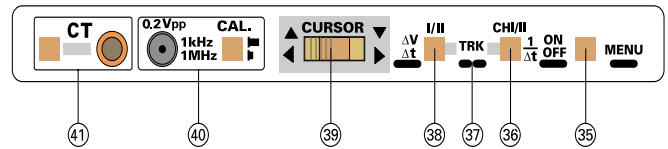

(35) MENU - Pushbutton

Pressing and holding the pushbutton activates the display of the **MAIN MENU**. It contains the submenus **SETUP** and **CALIBRATE**.

Once a menu is displayed, the following pushbuttons are of importance:

1. SAVE and RECALL (7) pushbutton.

Briefly pressing selects the submenu or an item within the submenu.

2. SAVE (7) pushbutton SET function.

Pressing and holding the **SAVE (7)** pushbutton calls (sets) the menu or the previously selected item. In those cases where the item is marked ON/Off the setting changes from **ON** to **OFF** or vice versa.

If "**PRESS SECURITY KEY**" is displayed, this function is available only for HAMEG authorized workshops. Press **AUTOSET (3)** to switch back to the menu.

3. AUTOSET (3) pushbutton.

Each time the **AUTOSET** pushbutton is pressed the menu switches back one step until **MAIN MENU** is displayed. Then pressing the **AUTOSET** pushbutton again switches the menu operation off and **AUTOSET** is set to the normal function.

(36)ON/OFF - CH I/II - 1/Δt

This pushbutton has several functions.

ON/OFF:

Pressing and holding the pushbutton switches both cursor lines on or off. As the cursor lines are part of the readout, they are visible only if the readout is switched on.

CH I/II:

This function **is required and available only in DUAL and XY mode in combination with ΔV (38)** measurement. Briefly pressing the button switches between channel I and channel II and vice versa.

In **DUAL** mode the measured result is displayed by the readout with "ΔV1: ..." or "ΔV2: ..." providing the deflection coefficient is calibrated. The settings of the cursors must relate to the signal of the selected channel.

In **XY** mode the instrument is automatically set to **ΔV** measurement. In this mode two signals are normally applied causing an X and a Y deflection. The deflection coefficient selected for each channel may be different, thus as in **DUAL** mode the **ΔV** cursor measurement requires a channel selection. Under channel I (Y signal) measuring condition the cursor lines are displayed as horizontal lines and the readout displays "ΔVY: ..." (calibrated). Briefly pressing the pushbutton changes to channel II (X signal) voltage measurement. Then the cursor lines are displayed as vertical lines and the readout indicates "ΔVX> ..." (uncalibrated).

In **CH I** or **CH II** mono mode, only one deflection coefficient is present and there is no requirement to select

Controls and Readout

between different deflection coefficients. Consequently the pushbutton is inactivated in combination with ΔV measurements.

1/ Δt :

If the ΔV function is not present, briefly pressing the button selects between time and frequency measurement which is not available in XY mode. The vertical cursor lines and the measurement result apply to the active timebase (A or B, resp. B in alternate timebase mode).

In calibrated timebase condition the readout displays " Δt ..." if time measurement is chosen. After switching over to 1/ Δt (frequency) "f:..." is displayed. If the timebase is uncalibrated the readout displays " $\Delta t > \dots$ " or "f < ...".

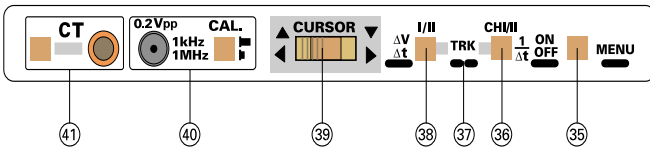

(37) TRK - CURSOR-Track function.

Briefly pressing simultaneously both buttons **ON/OFF - CHI/II - 1/ Δt (36)** and **I/II - $\Delta V/\Delta t$ (38)** switches over from single cursor line operation to track mode and vice versa.

In TRK (track) mode both cursor lines are indicated as active (both dotted lines uninterrupted).

(38) I/II - $\Delta V/\Delta t$ - Pushbutton with two functions.

I/II:

Briefly pressing this button changes the active (controllable) cursor in the sequence I - II - I, if TRK (track) mode is not active. The active cursor is indicated by a continuously dotted line. An interrupted dotted line indicates the inactive cursor.

$\Delta V/\Delta t$:

Pressing and holding this pushbutton changes from voltage to time (or frequency) measurement and vice versa. In XY mode the instrument is automatically set to ΔV .

ΔV :

Please note!

In all ΔV (voltage) measurement conditions, the division ratio of the probe(s) must be taken into account. The voltage value displayed in the readout must be multiplied by 100 if e.g. a x100 (100:1) probe is used. In case of x10 (10:1) probes, the probe factor can be automatically included (see item (28) and (32)).

item 1: Timebase mode.

(CH I or CH II single channel mode, DUAL and ADD)

In the voltage measurement condition, the cursors are displayed as horizontal lines and the result is displayed in the readout.

Single channel mode (channel I or channel II).

The ΔV measuring result is automatically related to the deflection coefficient of the active channel. The readout displays " $\Delta V1$..." or " $\Delta V2$...".

Dual mode.

The CURSOR lines must be set on the channel I or channel II signal. As the deflection coefficients may be

different, it will be required to select between the deflection coefficients of channel I and II. **Please note item (36) CHI/II.**

Addition (ADD) mode.

In **ADD** (addition) mode normally two input signals are displayed as one signal (sum or difference). As the result can only be determined if both (calibrated) deflection coefficients are equal, the **CHI/II (36)** selection function is deactivated. In that case the readout indicates " ΔV ..." without any additional channel information. Different deflection coefficient settings or uncalibrated deflection coefficient(s) are indicated in the readout as "**Y1** < **Y2**".

item 2: XY mode.

In XY mode the instrument is automatically set to ΔV measurement. The deflection coefficient selected for each channel may be different, thus as in DUAL mode the ΔV cursor measurement requires a channel selection. Under channel I (Y signal) measuring condition the cursor lines are displayed as horizontal lines and the readout displays " ΔVY ...". The cursor lines are displayed as vertical lines and the readout indicates " ΔVX ..." if the channel II deflection coefficient is chosen.

Δt :

In time or frequency measurement condition two vertical cursor lines are displayed. The measurement result is indicated as " Δt ..." (time measurement) or "f..." (frequency measurement). **Please note item (36) 1/ Δt .**

NOTE:

For frequency measurement, the distance between the cursors must equal exactly one signal period. In XY mode the timebase is switched off. Consequently time or frequency measurement is disabled.

(39) CURSOR - Center biased lever.

The active cursor line (in track mode: both lines) can be shifted in the required direction, until the graticule limits are reached. The directions are marked on the front panel and depend on the selected measurement (ΔU , Δt or 1/ Δt). Which of two shift speeds is used, depends on how far the **CURSOR** knob is pressed. With slight knob pressure the cursor line(s) moves slowly. If the knob is pressed to the full extent the cursor moves fast. If the knob is released it automatically reverts to the center position and the cursor shift stops.

(40) CAL. - Pushbutton and concentric socket.

A squarewave signal of 0.2Vpp $\pm 1\%$ is available from the socket for probe adjustment purposes. The signal frequency depends on the pushbutton setting. If the pushbutton is released it is approx. 1kHz and can be switched over (depressed) to approx. 1MHz. The pulse duty factor may deviate from 1:1 and the frequency is not calibrated.

(41) CT - Pushbutton and banana jack.

Pressing the pushbutton switches the instrument over from oscilloscope to component test mode and vice versa.

In component test mode, all controls are deactivated with the exception of the **CT** button, **AUTO SET (2)** and **INTENS (4)**. All LEDs except "**A**" or "**RO**" (associated with the INTENS knob) are dark. The readout displays only "**CT**" in this condition.

One test lead is connected to the CT socket. The second

test lead uses the ground socket (38). Please note "Component Tester".

The maximum test voltage is approx. 20Vpp under open circuit conditions, while the max. test current under short circuit condition is approx. 20mA.

Menu

The instrument software contains several menus. The controls regarding the menus are described under item MENU (35) in section "Controls and Readout".

The following menus, submenus and items within the submenus are available:

1. MAIN MENU

1.1 CALIBRATE

Information regarding this can be found in the section "Adjustments".

1.2 SETUP

This menu allows changes to the default settings regarding the instrument behavior during operation. The SETUP menu contains the submenu "MISCELLANEOUS" and "FACTORY".

1.2.1 MISCELLANEOUS contains:

1.2.1.1 CONTROL BEEP ON/OFF

In OFF condition the acoustic signal actuated by the control limits are switched off.

Note:

The default setting is ON. If different conditions are required the setting must be performed each time after switching the oscilloscope on.

1.2.1.2 ERROR BEEP ON/OFF

Acoustic signal indicating faulty control operation are suppressed in OFF condition.

Note:

The default setting is ON. If different conditions are required the setting must be performed each time after switching the oscilloscope on.

1.2.1.3 QUICK START ON/OFF

In condition ON the HAMEG logo, software information and check procedures will not be displayed after switching the instrument on and the instrument is quickly ready for operation.

1.2.1.4 TRIG.-SYMBOL ON/OFF

In most of the Yt (time base) modes the readout displays a trigger point symbol which will not be displayed in condition OFF.

1.2.1.5 DC REFERENCE ON/OFF

If ON is selected and Yt (time base) mode is present, the readout displays a ground symbol (⊥). This symbol eases the evaluation and determination of DC contents by indicating the 0 Volt reference position.

1.2.2 Factory

Attention!

Submenus are available only for HAMEG authorized service workshops.

First Time Operation

The following text assumes that the "SAFETY" section of this manual has been read carefully and understood.

Each time before the instrument is put into operation check that the oscilloscope is connected to protective earth. For that reason the power cable must be connected to the oscilloscope and the power outlet. Then the test lead(s) must be connected to the oscilloscope input(s). Check that the device under test is switched off and connect the test lead(s) to the test point(s). Then switch on the instrument and afterwards the device under test.

The oscilloscope is switched on by depressing the red **POWER** pushbutton. After a few seconds the **HAMEG** logo and the instrument software release is displayed on the screen. As long as the **HAMEG** logo is visible different internal checks are made. Thereafter the instrument will revert to its last used operating mode.

If after approx. 20 seconds no trace is visible, the **AUTO SET** pushbutton should be pressed briefly. This selects the Yt mode and medium trace and readout intensity (please note "AUTO SET"). Adjust **Y-POS.I** and **X-POS.** controls to center the baseline. Adjust **INTENS.** (intensity) and **FOCUS** controls for medium brightness and optimum sharpness (input(s) grounded) of the trace. The oscilloscope is now ready for use.

If the **AUTO SET** function was not used and only a spot appears (**CAUTION! CRT phosphor can be damaged**), reduce the intensity immediately and check that the XY mode is not selected (XY not displayed in the readout).

To obtain the maximum life from the cathode-ray tube, the minimum intensity setting necessary for the measurement in hand and the ambient light conditions should be used.

Particular care is required when a single spot is displayed, as a very high intensity setting may cause damage to the fluorescent screen of the CRT. Switching the oscilloscope off and on at short intervals stresses the cathode of the CRT and should therefore be avoided.

The instrument is so designed that even incorrect operation will not cause serious damage.

Trace Rotation TR

In spite of Mumetal-shielding of the CRT, effects of the earth's magnetic field on the horizontal trace position cannot be completely avoided. This is dependent upon the orientation of the oscilloscope on the place of work. A centered trace may not align exactly with the horizontal center line of the graticule. A few degrees of misalignment can be corrected by a potentiometer accessible through an opening on the front panel marked TR.

Probe compensation and use

To display an undistorted waveform on an oscilloscope, the probe must be matched to the individual input impedance of each vertical amplifier.

For this purpose a square wave signal with a very fast rise time and minimum overshoot should be used, as the sinusoidal contents cover a wide frequency range.

The built-in calibration generator provides a square wave signal with a very fast risetime (<4ns), and switch-selectable

First Time Operation

frequencies of approx. 1kHz and 1MHz from the output socket below the CRT screen. As the squarewave signals are used for probe compensation adjustments, neither the frequency accuracy nor the pulse duty factor are of importance and therefore not specified.

The output provides 0.2Vpp \pm 1% (tr <4ns) for 10:1 probes. When the Y deflection coefficient is set to 5mV/div, the calibration voltage corresponds to a vertical display of 4 divisions (10:1 probe).

The output socket has an internal diameter of 4.9mm to accommodate the internationally accepted shielding tube diameter of modern Probes and F-series slimline probes. Only this type of construction ensures the extremely short ground connections which are essential for an undistorted waveform reproduction of non-sinusoidal high frequency signals.

Adjustment at 1kHz

The C-trimmer adjustment (low frequency) compensates the capacitive loading on the oscilloscope input. By this adjustment, the capacitive division assumes the same ratio as the ohmic voltage divider to ensure the same division ratio for high and low frequencies, as for DC. (For 1:1 probes or switchable probes set to 1:1, this adjustment is neither required nor possible). A baseline parallel to the horizontal graticule lines is essential for accurate probe adjustments. (See also "Trace rotation TR").

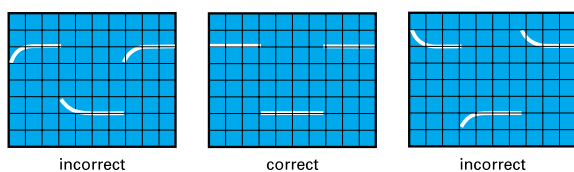

Connect the probes (Types **HZ51**, **52**, **54**, or **HZ36**) to the CH I input. Set the deflection coefficient to 5mV/div and the input coupling to DC. The time deflection coefficient should be set to 0.2ms/div. All deflection coefficients should be calibrated. Plug the probe tip into the calibrator output socket.

Approximately 2 complete waveform periods are displayed on the CRT screen. The compensation trimmer should be adjusted. The location of the low frequency compensation trimmer can be found in the probe information sheet. Adjust the trimmer with the insulated screwdriver provided, until the tops of the square wave signal are exactly parallel to the horizontal graticule lines (see 1kHz diagram). The signal height should then be 4div \pm 0.16div (= 4% (oscilloscope 3% and probe 1%). During this adjustment, the signal edges will remain invisible.

Adjustment at 1MHz

Probes HZ51, 52 and 54 can also be HF-compensated. They incorporate resonance de-emphasizing networks (R-trimmer in conjunction with inductances and capacitors) which permit probe compensation in the range of the upper frequency limit of the vertical oscilloscope amplifier. Only this compensative adjustment ensures optimum utilization of the full bandwidth, together with constant group delay at the high frequency end, thereby reducing characteristic transient distortion near the leading edge (e.g. overshoot, rounding, ringing, holes or bumps) to an absolute minimum.

Using the probes **HZ51**, **52** and **54**, the full bandwidth of the oscilloscope can be utilized without risk of unwanted waveform distortion.

Prerequisite for this HF compensation is a square wave generator with fast risetime (typically 4ns), and low output impedance (approx. 50 Ω), providing 0.2V at a frequency of approx. 1MHz. The calibrator output of this instrument meets these requirements when the CAL. pushbutton is depressed.

Connect the probe to **CHI** input. Depress the CAL. pushbutton for 1MHz. Operate the oscilloscope as described under 1kHz but select for 0.2 μ s/div time deflection coefficient setting.

Insert the probe tip into the output socket. A waveform will be displayed on the CRT screen, with leading and trailing edges clearly visible. For the HF-adjustment now to be performed, it will be necessary to observe the rising edge as well as the upper left corner of the pulse top. The location of the high frequency compensation trimmer(s) can also be found in the probe information sheet. These R-trimmer(s) have to be adjusted such that the beginning of the pulse is as straight as possible. Overshoot or excessive rounding are unacceptable. The adjustment is relatively easy if only one adjusting point is present. In case of several adjusting points the adjustment is slightly more difficult, but gives a better result. The rising edge should be as steep as possible, with a pulse top remaining as straight and horizontal as possible.

After completion of the HF-adjustment, the signal amplitude displayed on the CRT screen should have the same value as during the 1kHz adjustment.

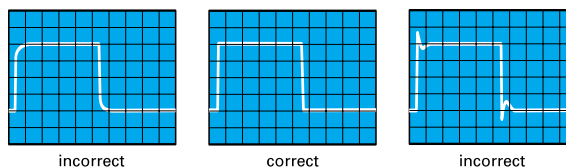

Probes other than those mentioned above, normally have a larger tip diameter and may not fit into the calibrator output.

Whilst it is not difficult for an experienced operator to build a suitable adapter, it should be pointed out that most of these probes have a slower risetime with the effect that the total bandwidth of scope together with probe may fall far below that of the oscilloscope. Furthermore, the HF-adjustment feature is nearly always missing so that waveform distortion can not be entirely excluded. The adjustment sequence must be followed in the order described, i.e. first at 1kHz, then at 1MHz. The calibrator frequencies should not be used for timebase calibration. The pulse duty cycle deviates from 1:1 ratio.

Prerequisites for precise and easy probe adjustments, as well as checks of deflection coefficients, are straight horizontal pulse tops, calibrated pulse amplitude, and zero-potential at the pulse base. Frequency and duty cycle are relatively uncritical. For interpretation of transient response, fast pulse risetimes and low-impedance generator outputs are of particular importance. Providing these essential features, as well as switch-selectable output-frequencies, the calibrator of the instrument can, under certain conditions, replace expensive squarewave generators when testing or compensating wideband-attenuators or -amplifiers. In such a case, the input of an appropriate circuit will be connected to the CAL.-output via a suitable probe.

The voltage provided at a high-impedance input (1M Ω || 15-30pF) will correspond to the division ratio of the probe used (10:1 = 20mVpp output). Suitable probes are **HZ51**, **52**, and **54**.

Operating modes of the vertical amplifiers in Yt mode

The most important controls regarding the operation modes of the vertical amplifiers are the pushbuttons: **CH I (17)**, **DUAL (18)** and **CH II (21)**. Their functions are described in the section “**Controls and Readout**”.

In most cases oscilloscopes are used to display signals in Yt mode. Then the signal amplitude deflects the beam in vertical direction while the timebase causes an X deflection (from left to right) at the same time. Thereafter the beam becomes blanked and fly back occurs.

The following Yt operation modes are available:

- Single channel operation of channel I (Mono CH I).
- Single channel operation of channel II (Mono CH II).
- Two channel operation of channel I and channel II (DUAL).
- Two channel operation of channel I and channel II -displaying the algebraic result as the sum or difference - (ADD).

The way the channel switching is determined in **DUAL** mode depends on the timebase setting and is described in the section “**Controls and Readout**”.

In ADD mode the signals of both channels are algebraically added and displayed as one signal. Whether the resulting display shows the sum or difference is dependent on the phase relationship or the polarity of the signals and on the invert function.

In ADD mode the following combinations are possible for

In-phase input voltages:

- No invert function active = sum.
- One invert function active = difference.
- Both invert functions (if available) active = sum.

Antiphase input voltages:

- No invert function active = difference.
- One invert function active = sum.
- Both invert functions (if available) active = difference.

In the **ADD** mode the vertical display position is dependent upon the **Y-POS.** setting of both channels. The same Y deflection coefficient is normally used for both channels with algebraic addition.

Please note that the Y-POS. settings are also added but are not affected by the INV setting.

Differential measurement techniques allow direct measurement of the voltage drop across floating components (both ends above ground). Two identical probes should be used for both vertical inputs. In order to avoid ground loops, use a separate ground connection and do not use the probe ground leads or cable shields.

X-Y Operation

The most important control regarding this operation mode is the **DUAL - XY (18)** pushbutton (**please note section “Controls and Readout”**).

In XY mode the timebase is deactivated. The signal applied to the input of channel II - front panel marking **HOR. INP. (X)** - causes the X deflection. The input related controls (**AC/DC**,

GD pushbutton and the **VOLTS/DIV** knob) consequently affect the X deflection. For X position alteration, the **X-POS.** control knob must be used, as the **Y-POS. II** control is automatically deactivated. The input deflection coefficient ranges are the same for both channels, because the **X x10** magnifier is inactive in XY mode.

The bandwidth of the X amplifier, is lower than the Y amplifier and the phase angle which increases with higher frequencies, must be taken into account (please note data sheet).

The inversion of the X-input signal is not possible. Lissajous figures can be displayed in the X-Y mode for certain measuring tasks:

- Comparing two signals of different frequency or bringing one frequency up to the frequency of the other signal. This also applies for whole number multiples or fractions of the one signal frequency.
- Phase comparison between two signals of the same frequency.

Phase comparison with Lissajous figures

The following diagrams show two sine signals of the same frequency and amplitude with different phase angles. Calculation of the phase angle or the phase shift between the X and Y input voltages (after measuring the distances a and b on the screen) is quite simple with the following formula, and a pocket calculator with trigonometric functions.

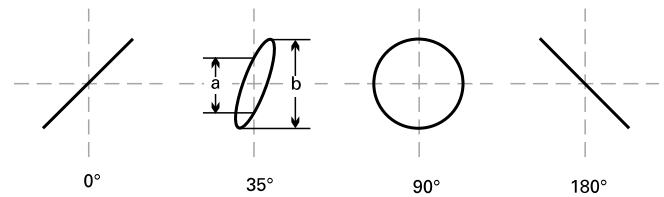

Apart from the reading accuracy, the signal height has no influence on the result.

$$\sin \varphi = \frac{a}{b}$$

$$\cos \varphi = \sqrt{1 - \left(\frac{a}{b}\right)^2}$$

$$\varphi = \arcsin \frac{a}{b}$$

The following must be noted here:

- Because of the periodic nature of the trigonometric functions, the calculation should be limited to angles $\leq 90^\circ$. However here is the advantage of the method.
- Due to phase shift, do not use a too high test frequency.
- It cannot be seen as a matter of course from the screen display if the test voltage leads or lags the reference voltage.

A CR network before the test voltage input of the oscilloscope can help here. The $1M\Omega$ input resistance can equally serve as R here, so that only a suitable capacitor C needs to be connected in series. If the aperture width of the ellipse is increased (compared with C short-circuited), then the test voltage leads the reference voltage and vice versa. This applies only in the region up to 90° phase shift. Therefore C should be sufficiently large and produce only a relatively small just observable phase shift.

First Time Operation

Should both input voltages be missing or fail in the X-Y mode, a very bright dot is displayed on the screen. This dot can burn into the phosphor at a too high brightness setting (**INTENS. knob**) which causes either a lasting loss of brightness, or in the extreme case, complete destruction of the phosphor at this point.

Phase difference measurement in DUAL mode (Yt)

Phase differences between two input signals of the same frequency and shape can be measured very simply on the screen in Dual mode. The timebase should be triggered by the reference signal (phase position 0). The other signal can then have a leading or lagging phase angle.

For greatest accuracy adjust the timebase for slightly over one period and approximately the same height of both signals on the screen. The Y deflection coefficients, the timebase coefficients and the trigger level setting can be used for this adjustment, without influence on the result. Both base lines are set onto the horizontal graticule center line using the Y-POS. knobs before the measurement. With sinusoidal signals, observe the zero (crossover point) transitions; the sine peaks are less accurate.

If a sine signal is noticeably distorted by even harmonics, or if a DC voltage is present, AC coupling is recommended for both channels. If it is a question of pulses of the same shape, read off at steep edges.

It must be noted that the phase difference cannot be determined if alternate triggering is selected.

Phase difference measurement in DUAL mode

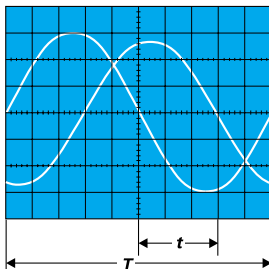

$$u = U_T \cdot \sin \Omega t + 0,5m \cdot U_T \cdot \cos(\Omega - \omega) t - 0,5m \cdot U_T \cdot \cos(\Omega + \omega)t$$

where

$$\begin{aligned} U_T &= \text{unmodulated carrier amplitude} \\ \Omega &= 2\pi F = \text{angular carrier frequency} \\ \omega &= 2\pi f = \text{modulation angular frequency} \\ m &= \text{modulation factor} \end{aligned}$$

The lower side frequency $F-f$ and the upper side frequency $F+f$ arise because of the modulation apart from the carrier frequency F .

Figure 1
Amplitude and frequency spectrum for AM display ($m = 50\%$)

The display of an amplitude-modulated HF oscillation can be evaluated with the oscilloscope provided the frequency spectrum is inside the oscilloscope bandwidth. The timebase is set so that several cycles of the modulation frequency are visible. Strictly speaking, triggering should be external with modulation frequency (from the AF generator or a demodulator). However, internal triggering is frequently possible with normal triggering using a suitable trigger level setting and possibly also using the time vernier (variable) adjustment.

Oscilloscope setting for a signal according to figure 2:

- Y: CH. I; 20mV/div; AC.
- TIME/DIV.: 0.2ms/div.
- Triggering: Normal; with LEVEL-setting; internal (or external) triggering.

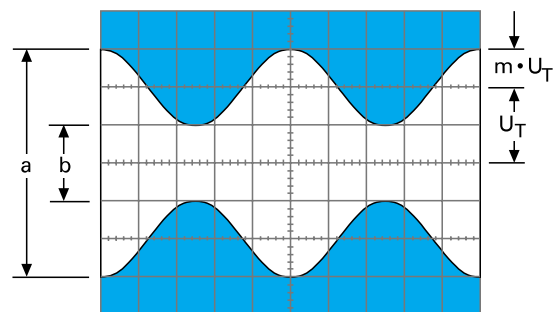

Figure 2
Amplitude modulated oscillation:
 $F = 1 \text{ MHz}$; $f = 1 \text{ kHz}$;
 $m = 50\%$; $U_T = 28.3 \text{ mV}_{\text{rms}}$.

If the two values a and b are read from the screen, the modulation factor is calculated from

$$m = \frac{a-b}{a+b} \quad \text{resp.} \quad m = \frac{a-b}{a+b} \cdot 100 [\%]$$

where

$$a = U_T (1+m) \quad \text{and} \quad b = U_T (1-m).$$

The variable controls for amplitude and time can be set arbitrarily in the modulation factor measurement. Their position does not influence the result.

t = horizontal spacing of the zero transitions in div
 T = horizontal spacing for one period in div

In the example illustrated, $t = 3 \text{ div}$ and $T = 10 \text{ div}$.

The phase difference in degrees is calculated from

$$\varphi^\circ = \frac{t}{T} \cdot 360^\circ = \frac{3}{10} \cdot 360^\circ = 108^\circ$$

$$\text{arc } \varphi^\circ = \frac{t}{T} \cdot 2\pi = \frac{3}{10} \cdot 2\pi = 1,885 \text{ rad}$$

Relatively small phase angles at lower frequencies can be measured more accurately in the X-Y mode with Lissajous figures.

Measurement of amplitude modulation

The momentary amplitude u at time t of a HF-carrier voltage, which is amplitude modulated without distortion by a sinusoidal AF voltage, is in accordance with the equation

Triggering and timebase

All controls regarding trigger and timebase are located on the right of the VOLTS/DIV. knobs. They are described in the section **“Controls and Readout”**.

Time related amplitude changes on a measuring signal (AC voltage) are displayable in Yt-mode. In this mode the signal voltage deflects the beam in vertical direction (Y) while the timebase generator moves the beam from the left to the right of the screen (time deflection = t).

Normally there are periodically repeating waveforms to be displayed. Therefore the timebase must repeat the time deflection periodically too. To produce a stationary display, the timebase must only be triggered if the signal height and slope condition coincide with the former timebase start conditions. A DC voltage signal can not be triggered as it is a constant signal with no slope.

Triggering can be performed by the measuring signal itself (internal triggering) or by an external supplied but synchronous voltage (external triggering).

The trigger voltage should have a certain minimum amplitude. This value is called the trigger threshold. It is measured with a sine signal. Except when external trigger is used the trigger threshold can be stated as vertical display height in div, at which the timebase generator starts, the display is stable, and the trigger indicator LED lights or flashes. The internal trigger threshold of the oscilloscope is given as $\leq 0.5\text{div}$. When the trigger voltage is externally supplied, it can be measured in V_{pp} at that input. Normally, the trigger threshold may be exceeded up to a maximum factor of 20.

The instrument has two trigger modes, which are characterized as Automatic Peak- and Normal-Triggering.

Automatic Peak (Value) -Triggering

Instrument specific information can be drawn from the items **NM - AT - $\int \setminus$ (11)** and **LEVEL (13)** in the section **“Controls and Readout”**.

This trigger mode is automatically selected after the **AUTOSET** pushbutton is pressed. As the peak value detection makes no sense in combination with **DC** and **TV** (television) signals, it is switched off automatically in **DC**, **TVL** and **TVF** trigger coupling conditions as well as in alternate trigger mode. In this case the automatic is still present, but a wrong trigger level setting causes an untriggered display.

In automatic trigger mode the sweep generator can run without a test signal or external trigger voltage. A base line will always be displayed even with no signal. With an applied AC signal the peak value triggering enables the user to select the voltage point on the trigger signal (trigger point), by the adjustment of the trigger level control. The control range depends on the peak to peak value of the signal. This trigger mode is therefore called Automatic Peak (Value)- Triggering. Operation of the scope needs only correct amplitude and timebase settings, for a constantly visible trace.

Automatic mode is recommended for all uncomplicated measuring tasks. However, automatic triggering is also the appropriate operation mode for the “entry” into difficult measuring problems, e.g. when the test signal is unknown relating to amplitude, frequency or shape. Presetting of all parameters is now possible with automatic triggering; the change to normal

triggering can follow thereafter.

The automatic triggering works above 20Hz. The failure of automatic triggering at frequencies below 20Hz is abrupt. However, it is not signified by the trigger indicator LED which is still blinking. Loss of triggering is best recognizable at the left screen edge (the start of the trace in differing display height).

The automatic peak (value) triggering operates over all variations or fluctuations of the test signal above 20Hz. However, if the pulse duty factor of a square-wave signal exceeds a ratio of 100:1, switching over to normal triggering will be necessary. Automatic triggering is practicable with internal and external trigger voltage.

Normal Triggering

The description of the most important control elements (**NM - AT - $\int \setminus$ (11)** and **LEVEL (13)**) is part of the section **“Controls and Readout”**.

With normal triggering, the sweep can be started by AC signals within the frequency range defined by the trigger coupling setting.

In the absence of an adequate trigger signal or when the trigger controls (particularly the trigger LEVEL control) are misadjusted, no trace is visible.

When using the internal normal triggering mode, it is possible to trigger at any amplitude point of a signal edge, even with very complex signal shapes, by adjusting the trigger LEVEL control. If the signal applied at the Y input is used for triggering (internal trigger source), its adjusting range is directly dependent on the display height, which should be at least 0.5div. If it is smaller than 1div, the trigger **LEVEL** adjustment needs to be operated with a sensitive touch. In the external normal triggering mode, the same applies to approx. 0.3V_{pp} external trigger voltage amplitude.

Other measures for triggering of very complex signals are the use of the timebase variable control and hold off time control, mentioned later.

$\int \setminus$ Slope

Please note item (11) in section “Controls and Readout” for instrument specific information.

The actual slope setting is displayed in the readout. The setting is not changed by the **AUTO SET** function. The slope setting can be changed in alternate- and B timebase mode for the B timebase trigger unit if the delay trigger function is active. The previous slope setting for the A timebase trigger is stored and still active. For further information **please note “Controls and Readout”**.

The timebase generator can be triggered by a rising or falling edge of the test signal. Whether the rising or the falling edge is used for triggering, depends on the slope direction setting. This is valid with automatic and normal triggering. The positive slope direction means an edge going from a negative potential and rising to a positive potential. This has nothing to do with zero or ground potential and absolute voltage values. The positive slope may also lie in a negative part of a signal.

However the trigger point may be varied within certain limits on the chosen edge using the LEVEL control. The slope direction is always related to the input signal and the non inverted display.

Triggering and timebase

Trigger coupling

Instrument specific information regarding this item can be noted in the "Data Sheet". The coupling setting (**TRIG. MODE (22)**) and indication are described under "**Controls and Readout**".

As the automatic triggering does not work below 20Hz, normal triggering should be used in DC and LF trigger coupling mode. The coupling mode and accordingly the frequency range of the trigger signal should meet the signal requirements.

AC: This is the most frequently used trigger mode. The trigger threshold increases below and above the frequency limits mentioned in the data sheet. This filter cuts off both the DC content of the trigger signal and the lowest frequency range.

DC: In this coupling mode the trigger signal is coupled galvanically to the trigger unit if normal triggering (NM) is present. Therefore there is no low frequency limit.

DC triggering is recommended if the signal is to be triggered with quite slow processes or if pulse signals with constantly changing pulse duty factors have to be displayed.

HF: In this coupling mode the transmission range equals a high pass filter. It cuts off the DC content of the trigger signal and the lower frequency range.

NR: Decreases the maximum trigger bandwidth for high frequency signals. As in DC coupling condition, lower frequency signal parts are not affected if normal triggering (NM) is selected.

LF: The LF coupling (low pass filter function) is often more suited for low-frequency signals than the DC coupling, because the (white) noise in the trigger voltage is strongly suppressed. So jitter or double-triggering of complex signals is avoidable or at least reduced, in particular with very low input voltages.

TV-L: The built-in active TV-Sync-Separator provides the separation of line sync pulses from the video signal. Even distorted video signals are triggered and displayed in a stable manner. This mode is described under paragraph "Triggering of video signals".

TV-F: The built-in active TV-Sync-Separator also provides the separation of frame sync pulses from the video signal. Even distorted video signals are triggered and displayed in a stable manner.

This mode is described under paragraph "**Triggering of video signals**".

Triggering of video signals

In TV-L and TV-F trigger coupling mode the instrument is automatically set to automatic triggering and the trigger point indicator is switched off. As only the separated synchronisation pulses are used for triggering the relationship between the displayed signal and the trigger signal is lost. In TV-F mode interference may occur if chopped DUAL mode is chosen or the readout is active. Video signals are triggered in the automatic mode. The internal triggering is virtually independent of the display height, but the sync pulse must exceed

0.5div height.

The polarity of the synchronization pulse is critical for the slope selection. If the displayed sync pulses are above the picture (field) contents (leading edge positive going), then the slope setting for positive going edges must be chosen. In the case of sync pulses below the field/line, the leading edge is negative and consequently the slope selection must be set for falling edges. Since the invert function may cause a misleading display, it must not be activated.

TVF: On the 2ms/div setting and field TV triggering selected, 1 field is visible if a 50 fields/s signal is applied. If minimum hold off time is chosen, it triggers without line interlacing affects caused by the consecutive field.

More details in the video signal become visible if in alternate or B timebase mode the B timebase speed is increased above the A timebase speed. If the timebase is set to 5ms/div 2.5 frames are visible. The time delay for the B timebase can then be used to select any line(s) to be displayed expanded on the screen. The influence of the integrating network which forms a trigger pulse from the vertical sync pulses may become visible under certain conditions.

Due to the integrating network time constant not all vertical sync pulses starting the trace are visible.

TVL: On the 10µs/div setting and line TV triggering selected, approx. 1½ lines are visible. Those lines originate from the odd and even fields at random.

The sync-separator-circuit also operates with external triggering. It is important that the voltage range (0.3Vpp to 3Vpp) for external triggering should be noted. Again the correct slope setting is critical, because the external trigger signal may not have the same polarity or pulse edge as the test signal displayed on the CRT. This can be checked, if the external trigger voltage itself is displayed first (with internal triggering).

In most cases, the composite video signal has a high DC content. With constant video information (e.g. test pattern or color bar generator), the DC content can be suppressed easily by AC input coupling of the oscilloscope amplifier. With a changing picture content (e.g. normal program), DC input coupling is recommended, because the display varies its vertical position on screen with AC input coupling at each change of the picture content. The DC content can be compensated using the **Y-POS.** control so that the signal display lies in the graticule area. Then the composite video signal should not exceed a vertical height of 6div.

Line triggering (~)

The instrument specific information regarding this mode is part of the section "**Controls and Readout**" paragraph **TRIG. MODE (22)**.

This trigger mode is present if the trigger coupling information in the readout displays "**TR:~**". The symbol can be changed by 180° by using the trigger slope (**11**) pushbutton. The trigger point symbol is inactive in line/mains trigger mode as there is no direct amplitude relationship between the trigger voltage and the signal voltage.

A voltage originating from mains/line (50 to 60Hz) is used for

triggering purposes if the trigger coupling is set to \sim . This trigger mode is independent of amplitude and frequency of the Y signal and is recommended for all mains/line synchronous signals. This also applies within certain limits, to whole number multiples or fractions of the line frequency. Line triggering can also be useful to display signals below the trigger threshold (less than 0.5div). It is therefore particularly suitable for measuring small ripple voltages of mains/line rectifiers or stray magnetic field in a circuit. In this trigger mode the slope direction pushbutton selects the positive or negative portion of the line/mains sinewave.

The trigger level control can be used for trigger point adjustment. Magnetic leakage (e.g. from a power transformer) can be investigated for direction and amplitude using a search or pick-up coil. The coil should be wound on a small former with maximum turns of thin lacquered wire and connected to a BNC connector (for scope input) via a shielded cable. Between cable and BNC center conductor a resistor of at least 100Ω should be series-connected (RF decoupling). Often it is advisable to shield the surface of the coil. However, no shorted turns are permissible. Maximum, minimum, and direction to the magnetic source are detectable at the measuring point by turning and shifting the coil.

Alternate triggering

This trigger mode can be selected in DUAL mode by pressing and holding the **TRIG.** pushbutton (19) if the preconditions are met (**please note "Controls and Readout"**). In the case of chopped DUAL mode, selecting alternate trigger mode automatically sets the instrument to alternate DUAL mode. The trigger point symbol and the peak value detection (in automatic trigger mode) are internally deactivated. Only the following trigger coupling modes are available in alternate trigger mode: AC, DC, NR, HF and LF.

With alternate triggering it is possible to trigger two signals which are different in frequency (asynchronous). Each input signal must be of sufficient height to enable trigger. To avoid trigger problems due to different DC voltage components, AC input coupling for both channels is recommended.

The internal trigger source is switched in alternate trigger mode in the same way as the channel switching system in DUAL alternate mode, i.e. after each timebase sweep. Phase difference measurement is not possible in this trigger mode as the trigger level and slope setting are equal for both signals. Even with 180° phase difference between both signals, they appear with the same slope direction. If signals are applied with a high frequency ratio (difference), the trace intensity then becomes reduced if the timebase is set to smaller time coefficients (faster sweep). This happens as the number of sweeps does not increase because it depends on the lower frequency signal, but with a faster sweep the phosphor becomes less activated.

External triggering

The external trigger input is activated with the aid of the **TRIG.** (19) pushbutton (**see "Controls and Readout"**), if the trigger coupling is not set to line/mains trigger coupling. Then the internal trigger source is deactivated.

As the external trigger signal applied at the TRIG. EXT socket normally has no relation to the signal height of the displayed signal, the trigger point symbol is switched off. The external trigger voltage must have a minimum amplitude of 0.3Vpp and should not increase above 3Vpp. The input impedance of

the TRIG. EXT. socket is approx. $1M\Omega \parallel 15pF$.

The maximum input voltage of the input circuit is 100V (DC+peak AC).

The external trigger voltage may have a completely different form from the test signal voltage, but must be synchronous with the test signal. Triggering is even possible in certain limits with whole number multiples or fractions of the test frequency.

It must be noted that a different phase angle between the measuring and the triggering signal may cause a display not coinciding with the slope selection setting.

The trigger coupling selection can also be used in external triggering mode.

Trigger indicator "TR"

The following description applies to the **"TR" LED**. **Please note item (12) under "Controls and Readout"**.

An LED on condition indicates that the trigger signal has a sufficient amplitude and the trigger level control setting is correct. This is valid with automatic and with normal triggering. By observing the trigger LED, sensitive trigger level adjustment is possible when normal triggering is used, particularly at very low signal frequencies. The indication pulses are of only 100ms duration.

Thus for fast signals the LED appears to glow continuously, for low repetition rate signals, the LED flashes at the repetition rate or at a display of several signal periods not only at the start of the sweep at the left screen edge, but also at each signal period. In automatic triggering mode the sweep generator starts repeatedly without test signal or external trigger voltage. If the trigger signal frequency decreases the trigger automatic repetition frequency the sweep generator starts without awaiting the trigger pulse. This causes an untriggered display and a flashing trigger LED.

HOLD OFF-time adjustment

For instrument specific information **please note DEL.POS. - HO (23) in section "Controls and Readout"**.

If it is found that a trigger point cannot be found on extremely complex signals, even after careful adjustment of the trigger level control, a stable display may often be obtained using the holdoff control. This facility varies the holdoff time between two sweep periods approx. up to the ratio 10:1. Pulses or other signal waveforms appearing during this off period cannot trigger the timebase. Particularly with burst signals or aperiodic pulse trains of the same amplitude, the start of the sweep can be delayed until the optimum or required time.

A very noisy signal or a signal with a higher interfering frequency is at times displayed double. It is possible that trigger level adjustment only controls the mutual phase shift, but not the double display. The stable single display of the signal, required for evaluation, is easily obtainable by expanding the hold off time until one signal is displayed.

A double display is possible with certain pulse signals, where the pulses alternately show a small difference of the peak amplitudes. Only a very exact trigger level adjustment makes a single display possible. The use of the holdoff control simplifies the right adjustment.

After specific use the holdoff control should be reset into its

calibration detent (fully ccw), otherwise the brightness of the display is reduced drastically. The function is shown in the following figures.

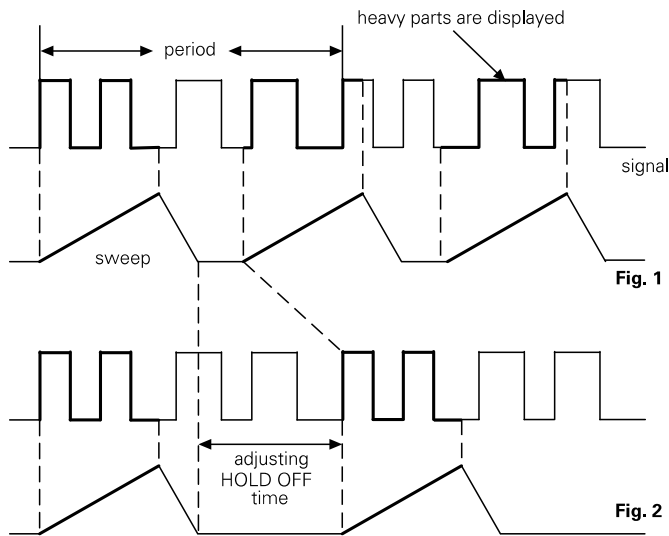

Fig. 1 shows a case where the holdoff control is in the minimum position and various different waveforms are overlapped on the screen, making the signal observation unsuccessful. Fig. 2 shows a case where only the desired parts of the signal are stably displayed.

B-Timebase (2nd Timebase)/ Triggering after Delay

Please note instrument specific information in section "Controls and readout". The most important controls regarding this mode are **A/ALT - B (25), DEL.TRIG. - VAR. (26), TIME/DIV. (24), DEL. POS.- HO (23) and TRS (9).**

As mentioned before, triggering starts the timebase sweep and unblanks the beam. After the maximum X deflection to the right, the beam is blanked and flies back to the (left) start position. After the hold off time has elapsed the sweep is started automatically by the automatic trigger or the next trigger signal. In normal triggering mode the automatic trigger is switched off and the sweep will only start on receipt of a trigger signal. As the trigger point is always at the trace start position, trace expansion in X direction with the aid of the timebase is limited to the display always from the trace start.

Parts of the signal to be expanded which are displayed near the trace end (right side of the screen) are lost when the timebase speed is increased (time coefficient reduced). The X expansion by 10 may also be used, but again the expansion factor is limited. The B timebase solves such problems.

First the A time coefficient should be in a suitable setting to display a complete signal period. After setting the instrument to alternate timebase mode (A and B), the signal part to be expanded must be selected with the aid of the intensified sector on the A timebase trace. The B timebase deflection coefficient should be at least a tenth of the A time coefficient.

Higher A/B ratios (e.g. A: 1ms/div, B: 1µs/div = 1000fold expansion) result in a drastically reduced B trace intensity. Within certain limits this can be compensated by the intensity setting. To avoid high contrast between the A and B timebase trace, change from alternate (A and B) to B timebase mode. Then the A trace is invisible.

The start position of the intensified sector on the A trace can be stated as the delay time. It is related to the A trace start and the A time coefficient.

The delay function delays the B trace start by a variable time from the A trigger point. This allows the sweep to begin on any portion of a signal (except the first millimeters). If the display shows jitter, it is possible to select triggering of the B timebase after the elapsed delay time.

Auto Set

The instrument specific information regarding this function is part of the section "Controls and Readout" paragraph **AUTO SET (2)**. As also mentioned in that section all controls are electronically selected with the exception of the **POWER** and calibrator frequency (CAL 1kHz/1MHz) pushbuttons as well as the **FOCUS** and **TR** (trace rotation) control.

Thus automatic signal related instrument set up in Yt (timebase) mode is possible. In most cases no additional manual instrument setting is required.

Briefly pressing the **AUTO SET** pushbutton causes the instrument to switch over to the last Yt mode settings regarding CH I, CH II and DUAL. If the instrument was operated in Yt mode, the actual setting will not be affected with the exception of ADD mode which will be switched off. At the same time the attenuator(s) (VOLTS/DIV) are automatically set for a signal display height of approx. 6 div in mono channel mode or if in DUAL mode for approx. 4 div height for each channel. This and the following explanation regarding the automatic time coefficient setting assumes that the pulse duty factor of the input signal is approx. 1:1. The time deflection coefficient is also set automatically for a display of approx. 2 signal periods. The timebase setting occurs randomly if complex signals consisting several frequencies e.g. video signals are present.

If cursor voltage measurement is selected, AUTOSSET also affects the position of the CURSOR lines. Please note AUTOSSET (2) in section "Controls and Readout".

AUTO SET sets the instrument automatically to the following operating conditions:

- AC or DC input coupling unaltered or in GD condition the previously used setting
- Internal triggering (channel I or channel II)
- Automatic peak (value) triggering
- Trigger level in electrical midrange position
- Y deflection coefficient(s) calibrated
- A timebase deflection coefficient calibrated
- AC trigger coupling (except DC trigger coupling)
- Alternate or B timebase mode switched off
- X x10 magnifier switched off
- Automatic X and Y position settings
- A visible trace and readout intensities.

If DC trigger coupling had been selected, AC trigger coupling will not be chosen and the automatic trigger is operative without the peak value detection.

The X position is set to the CRT center as well as the Y position in CH I or CH II mode. **Small deviations due to tolerances of the CRT and other components are unavoidable.** In DUAL mode the channel I trace is set to the upper half and the channel II trace to the lower half of the CRT.

The 1mV/div and 2mV/div deflection coefficients will not be

selected by AUTO SET as the bandwidth is reduced on these settings.

Attention!

If a signal is applied with a pulse duty factor of approx. 400:1 or larger, an automatic signal display cannot be performed. The pulse duty factor causes too low a Y deflection coefficient (sensitivity too high) and too high a time deflection coefficient (timebase speed too slow) and results in a display in which only the base-line is visible.

In such cases it is recommended to select normal triggering and to set the trigger point approx. 0.5div above or below the trace. If under one of these conditions the trigger indicator LED is lit, this indicates the presence of a signal. Then both the time coefficient and Y deflection coefficient should be reduced. Please note that a reduction in intensity may occur, which could result in a blank screen when the physical limits are reached.

Component Tester

General

The instrument specific information regarding the control and terminals are part of **item (40)** in section **“Controls and Readout”**.

The instrument has a built-in electronic Component Tester, which is used for instant display of a test pattern to indicate whether or not components are faulty. It can be used for quick checks of semiconductors (e.g. diodes and transistors), resistors, capacitors, and inductors. Certain tests can also be made to integrated circuits. All these components can be tested individually, or in circuit provided that it is unpowered. The test principle is fascinatingly simple. A built-in generator delivers a sine voltage, which is applied across the component under test and a built-in fixed resistor. The sine voltage across the test object is used for the horizontal deflection, and the voltage drop across the resistor (i.e. current through test object) is used for vertical deflection of the oscilloscope. The test pattern shows a current-voltage characteristic of the test object.

The measurement range of the component tester is limited and depends on the maximum test voltage and current (please note data sheet). The impedance of the component under test is limited to a range from approx. 20Ω to $4.7k\Omega$. Below and above these values, the test pattern shows only short-circuit or open-circuit. For the interpretation of the displayed test pattern, these limits should always be born in mind. However, most electronic components can normally be tested without any restriction.

Using the Component Tester

After the component tester is switched on, the vertical preamplifier and the timebase generator are inoperative. A shortened horizontal trace will be observed. It is not necessary to disconnect scope input cables unless in-circuit measurements are to be carried out. For the component connection, two simple test leads with 4mm \varnothing banana plugs, and with test prod, alligator clip or sprung hook, are required.

The test leads are connected as described in section **“Controls and Readout”**.

Test Procedure

Caution!

Do not test any component in live circuitry - remove all grounds, power and signals connected to the component under test. Set up Component Tester as stated. Connect test leads across component to be tested. Observe oscilloscope display. Only discharged capacitors should be tested!

Test Pattern Displays

The “Test patterns” shows typical patterns displayed by the various components under test.

- Open circuit is indicated by a straight horizontal line.
- Short circuit is shown by a straight vertical line.

Testing Resistors

If the test object has a linear ohmic resistance, both deflecting voltages are in the same phase. The test pattern expected from a resistor is therefore a sloping straight line. The angle of slope is determined by the resistance of the resistor under test. With high values of resistance, the slope will tend towards the horizontal axis, and with low values, the slope will move towards the vertical axis. Values of resistance from 20Ω to $4.7k\Omega$ can be approximately evaluated. The determination of actual values will come with experience, or by direct comparison with a component of a known value.

Testing Capacitors and Inductors

Capacitors and inductors cause a phase difference between current and voltage, and therefore between the X and Y deflection, giving an ellipse-shaped display. The position and opening width of the ellipse will vary according to the impedance value (at 50Hz) of the component under test.

A horizontal ellipse indicates a high impedance or a relatively small capacitance or a relatively high inductance.

A vertical ellipse indicates a small impedance or a relatively large capacitance or a relatively small inductance.

A sloping ellipse means that the component has a considerable ohmic resistance in addition to its reactance.

The values of capacitance of normal or electrolytic capacitors from $0.1\mu\text{F}$ to $1000\mu\text{F}$ can be displayed and approximate values obtained. More precise measurement can be obtained in a smaller range by comparing the capacitor under test with a capacitor of known value. Inductive components (coils, transformers) can also be tested. The determination of the value of inductance needs some experience, because inductors have usually a higher ohmic series resistance. However, the impedance value (at 50Hz) of an inductor in the range from 20Ω to $4.7k\Omega$ can easily be obtained or compared.

Testing Semiconductors

Most semiconductor devices, such as diodes, Z-diodes, transistors, FETs can be tested. The test pattern displays vary according to the component type as shown in the figures below. The main characteristic displayed during semiconductor testing is the voltage dependent knee caused by the junction changing from the conducting state to the non conducting state. It should be noted that both the forward and the reverse characteristic are displayed simultaneously. This

Component Tester

is a two-terminal test, therefore testing of transistor amplification is not possible, but testing of a single junction is easily and quickly possible. Since the test voltage applied is only very low, all sections of most semiconductors can be tested without damage. However, checking the breakdown or reverse voltage of high voltage semiconductors is not possible. More important is testing components for open or short-circuit, which from experience is most frequently needed.

Testing Diodes

Diodes normally show at least their knee in the forward characteristic. This is not valid for some high voltage diode types, because they contain a series connection of several diodes. Possibly only a small portion of the knee is visible. Zener diodes always show their forward knee and, depending on the test voltage, their zener breakdown forms a second knee in the opposite direction. If the breakdown voltage is higher than the positive or negative voltage peak of the test voltage, it can not be displayed.

The polarity of an unknown diode can be identified by comparison with a known diode.

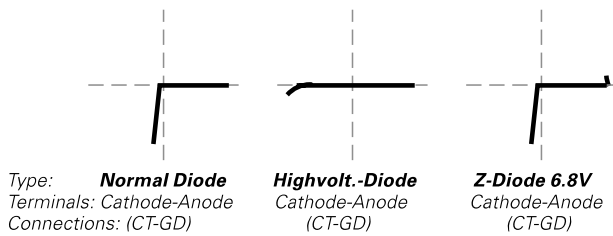

Testing Transistors

Three different tests can be made to transistors: base-emitter, base-collector and emitter-collector. The resulting test patterns are shown below.

The basic equivalent circuit of a transistor is a Z-diode between base and emitter and a normal diode with reverse polarity between base and collector in series connection. There are three different test patterns.

For a transistor the figures b-e and b-c are important. The figure e-c can vary; but a vertical line only shows short circuit condition. These transistor test patterns are valid in most cases, but there are exceptions to the rule (e.g. Darlington, FETs).

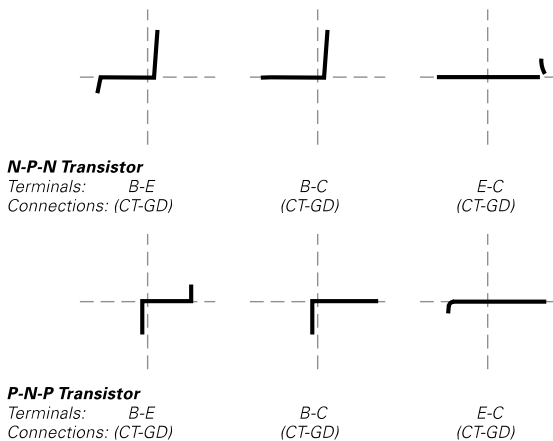

With the COMPONENT TESTER, the distinction between a P-N-P to an N-P-N transistor is discernible. In case of doubt, comparison with a known type is helpful. It should be noted

that the same socket connection (COMP. TESTER or ground) for the same terminal is then absolutely necessary.

A connection inversion effects a rotation of the test pattern by 180 degrees round about the center point of the scope graticule.

In-Circuit Tests

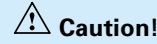

Caution!

During in-circuit tests make sure the circuit is dead. No power from mains/line or battery and no signal inputs are permitted.

Remove all ground connections including Safety Earth (pull out power plug from outlet). Remove all measuring cables including probes between oscilloscope and circuit under test. Otherwise both COMPONENT TESTER leads are not isolated against the circuit under test.

In-circuit tests are possible in many cases. However, they are not well defined. This is caused by a shunt connection of real or complex impedances - especially if they are of relatively low impedance at 50Hz - to the component under test, often results differ greatly when compared with single components.

In case of doubt, one component terminal may be unsoldered. This terminal should then not be connected to the ground socket avoiding hum distortion of the test pattern.

Another way is a test pattern comparison to an identical circuit which is known to be operational (likewise without power and any external connections). Using the test prods, identical test

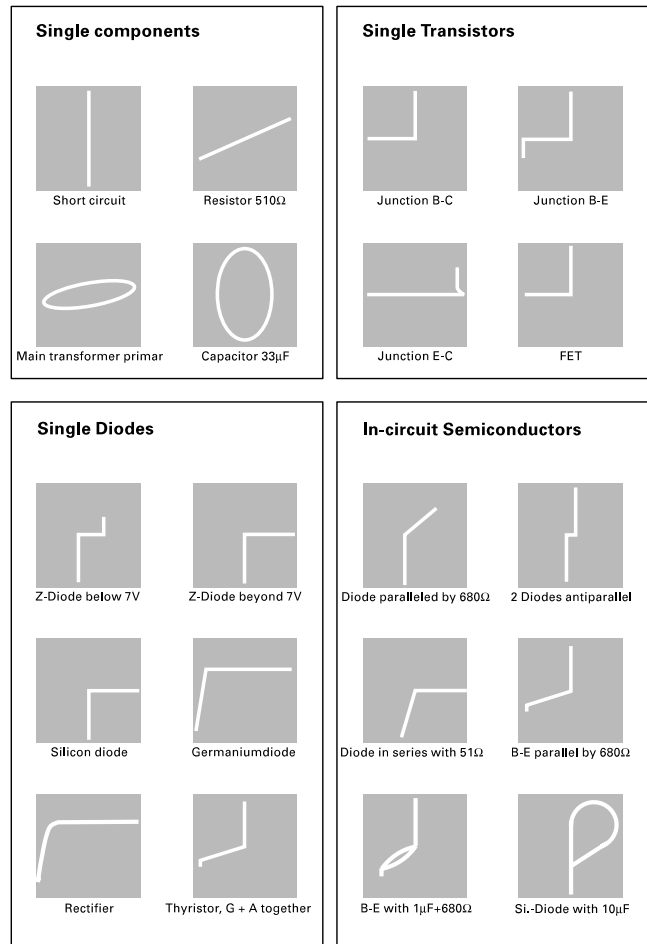

points in each circuit can be checked, and a defect can be determined quickly and easily.

Possibly the device itself under test contains a reference circuit (e.g. a second stereo channel, push-pull amplifier, symmetrical bridge circuit), which is not defective.

Adjustments

As described in the “Menu” section, the instrument’s software contains the submenu “CALIBRATE”. The controls regarding the menus are described under item **MENU (35)** in section “Controls and Readout”. After a warm up time of 20 minutes, the following items can be used by operators not equipped with precision instruments.

Both items are regarding the instrument’s temperature response under extreme environmental conditions. Similar effects can be caused by component failures as a result of the application of too high voltage at an input and therefore cannot be compensated by the automatic adjustment procedure. During these automatic adjustments there must be no signal applied to any input.

1. Y AMP (Y amplifier)

Corrects trace position changes of more than 0.5 division in Y direction, as a result of different attenuator settings in the range from 5mV/div to 5V/div when the input is not grounded but screened.

2. TRIGGER-AMP (trigger amplifier)

Compensates higher deviations of the trigger point (symbol) caused by switch over between AC and DC trigger coupling in condition internal triggering (Source: CH I or CH II), when a 50 kHz sine wave signal without DC content (AC input coupling recommended) is applied.

The instrument automatically adjusts and stores the adjustment values in a non volatile memory after calling the item. A new adjustment may be necessary after the temperature conditions have changed once again drastically.

RS232 Interface - Remote Control

Safety

Caution:

All terminals of the RS232 interface are galvanically connected with the oscilloscope and subsequently with protective (safety) earth potential.

Measurement on a high level reference potential is not permitted and endangers operator, oscilloscope, interface and peripheral devices. In case of disregard of the safety warnings contained in this manual, HAMEG refuses any liability regarding personal injury and/or damage of equipment.

Operation

The oscilloscope is supplied with a serial interface for control purposes. The interface connector (9 pole D- SUB female) is located on the rear of the instrument. Via this bidirectional port, the instrument parameter settings can be transmitted to, or received from a PC.

The maximum connecting cable length must be less than 3

meters and must contain 9 screened lines connected 1:1. The pin connection of the oscilloscope RS232 interface (9 pole D-SUB female) is determined as follows:

Pin

- 2** Tx data (data from oscilloscope to external device)
- 3** Rx data (data from external device to oscilloscope)
- 7** CTS (clear to send)
- 8** RTS (request to send)
- 5** Ground (reference potential - connected via the oscilloscope’s power cord with protective earth)



The maximum voltage swing at pin 2, 3, 7 and 8 is ±12 volt.

The RS232 parameter are:

N-8-2 (no parity bit, 8 data bits, 2 stop bits, RTS/CTS hardware protocol).

Baud-Rate Setting

After the first POWER UP (switching on of the oscilloscope) and the first command SPACE CR (20hex, 0Dhex) sent from the PC, the baud rate is recognized and set automatically between 110 baud and 115200 baud. The oscilloscope is then switched over to REMOTE control mode. The oscilloscope then transmits the RETURN CODE: 0 CR LF to the PC. In this status all settings (with the exception of those functions mentioned under “Controls and Readout”) can be controlled via the interface only.

The only ways to quit this status are:

- Switching the oscilloscope off, transmitting the command
- RM= 0 from the PC to the oscilloscope, or
- depressing the AUTO SET (LOCAL) pushbutton, if in unlocked condition (command LK=1... was not sent)

After the remote state has been switched off the RM-LED (3) is dark.

Please note:

A minimum time must elapse between the commands RM=1... (remote on) and RM=0... (remote off) and vice versa. The time can be calculated with the formula:

$$t_{min} = 2x(1/baud\ rate) + 60\mu s.$$

If at the beginning no SPACE CR command is recognizable, the oscilloscope pulls the TxD line low for approx. 0.2ms and causes a break on the PC.

Data Communication

After successfully being set to remote control mode, the oscilloscope is prepared for command reception.

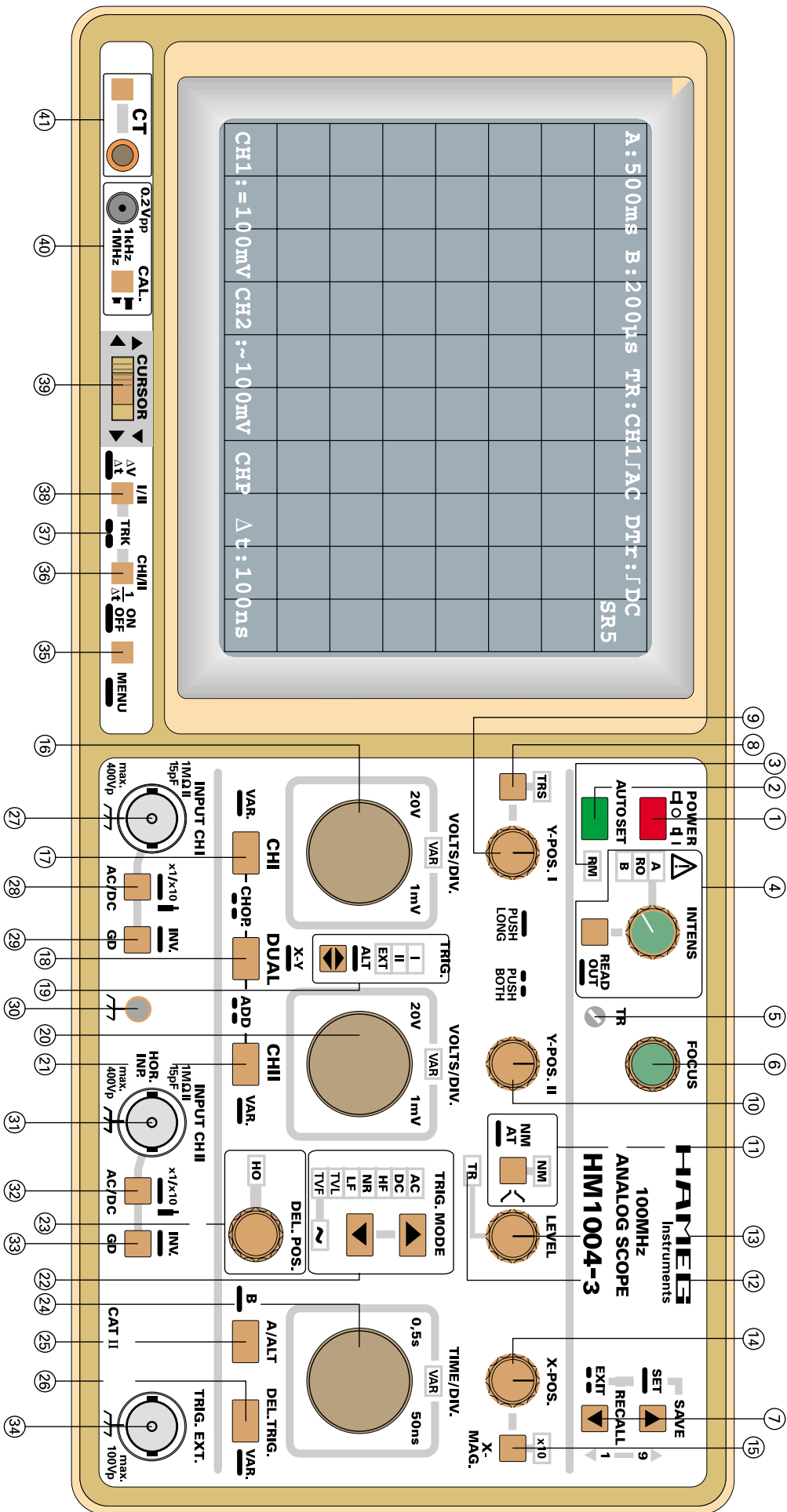

HAMEG[®]

Instruments

Oscilloscopes

Multimeters

Counters

Frequency Synthesizers

Generators

R- and LC-Meters

Spectrum Analyzers

Power Supplies

Curve Tracers

Time Standards

Printed in Germany

Germany

HAMEG GmbH

Industriestraße 6
63533 Mainhausen
Tel. (06182) 8909 - 0
Telefax (06182) 8909 - 30
E-mail: sales@hameg.de

HAMEG Service

Kelsterbacher Str. 15-19
60528 FRANKFURT am Main
Tel. (069) 67805 - 24
Telefax (069) 67805 - 31
E-mail: service@hameg.de

France

HAMEG S.a.r.l

5-9, av. de la République
94800-VILLEJUIF
Tél. (1) 4677 8151
Telefax (1) 4726 3544
E-mail: hamegcom@magic.fr

Spain

HAMEG S.L.

Villarroel 172-174
08036 BARCELONA
Teléf. (93) 4301597
Telefax (93) 321220
E-mail: email@hameg.es

Great Britain

HAMEG LTD

74-78 Collingdon Street
LUTON Bedfordshire LU1 1RX
Phone (01582)413174
Telefax (01582)456416
E-mail: sales@hameg.co.uk

United States of America

HAMEG, Inc.

266 East Meadow Avenue
EAST MEADOW, NY 11554
Phone (516) 794 4080
Toll-free (800) 247 1241
Telefax (516) 794 1855
E-mail: hamegny@aol.com

Hongkong

HAMEG LTD

Flat B, 7/F,
Wing Hing Ind. Bldg.,
499 Castle Peak Road,
Lai Chi Kok, Kowloon
Phone (852) 2 793 0218
Telefax (852) 2 763 5236
E-mail: hameghk@netvigator.com

41-1004-03E0